



WESTCAR s.r.l.

ROTOFLUID

Fluid Couplings



ATEX EXECUTION
UPON REQUEST



INDEX	page
Operating principles and features of ROTOFLUID couplings.....	5
Installation options: standard and reverse mounting	6
Characteristic curves of motors with or without fluid couplings.....	7
Fluid couplings with delay fill chamber	8
Characteristic starting curves	9
ROTOFLUID coupling versions: ALFA and BETA	10
ROTOFLUID coupling versions for ALFA - for in-line mounting and BETA - with pulley.....	11
ROTOFLUID coupling selection diagram.....	12
ROTOFLUID coupling selection table for 50 Hz, 60 Hz UNEL MEC electric motors.....	13
Tables for ROTOFLUID ALFA couplings	
ROTOFLUID ALFA for metric shaft K, SCF K, DCF K.....	14
ROTOFLUID ALFA for inches shaft KA, SCF KA, DCF KA.....	15
ROTOFLUID ALFA with flanged shaft K-S, SCF K-S, DCF K-S.....	16
ROTOFLUID ALFA with elastic couplings K, SCF K, DCF K with RNV/FRNV and AB.....	17
ROTOFLUID ALFA with elastic couplings and brake disc K, SCF K, DCF K with RNPV/FRNPV and ADB.....	18
ROTOFLUID ALFA with elastic couplings and brake drum K, SCF K, DCF K with RND/FRND and AFF	19
ROTOFLUID ALFA with gear couplings RE / REU WAG-G/GU, SCF WAG-G/GU, DCF WAG-G/GU.....	20
ROTOFLUID ALFA with brake drum FPU / brake disc DPU WAG-GPU/GPUU, SCF WAG-GPU/GPUU, DCF WAG-GPU/GPUU21	
ROTOFLUID ALFA with disc coupling HBSX KLM-RH, KLM-L.....	22
ROTOFLUID ALFA with brake drum FFL / brake disc DFL KLM-LF/LLF, SCF KLM-LF/LLF, DCF KLM-LF/LLF	23
ROTOFLUID ALFA for reverse mounting NY-FB, NY-SCF-FB, NY DCF-FB.....	24
ROTOFLUID ALFA with bell housing CKS.....	25
Tables couplings ROTOFLUID BETA	
ROTOFLUID BETA with and without delay fill chamber J, X, Z - SCF J, X, Z - DCF J, X, Z.....	26
COMPLEMENTS	
Bores and keyways table for fluid coupling shaft.....	27
Protection Plugs.....	28
Electric-Thermal switch equipment type ET	29
Device for speed and temperature control T09	30
Electronic device for overload control SCD.....	31
Screw puller VE type - pulling off system SE type.....	32
ROTOFLUID couplings Moment of inertia.....	33
OPTIONS.....	34
Instructions for filling and replacement of oil in ROTOFLUID coupling.....	35
ROTOFLUID coupling special versions.....	36
Fields of application	37
Technical sheet for coupling selection.....	38

INDEX OF TECHNICAL SHEETS

	page
10-002* EN ROTOFLUID coupling selection table for 50 Hz, 60 Hz UNEL MEC electric motors.....	13
10-019* EN Bores and keyways table for fluid coupling shaft.....	27
10-035* EN ROTOFLUID couplings Moment of inertia.....	33
10-037* EN Operating principles and features of ROTOFLUID couplings.....	5
10-038* EN Installation options: standard and reverse mounting.....	6
10-052* EN Fields of application.....	37
10-057* EN ROTOFLUID coupling versions for ALFA - for in-line mounting and BETA - with pulley.....	11
10-059* EN Technical sheet for coupling selection.....	38
10-060* EN OPTIONS.....	34
10-061* EN Characteristic curves of motors with or without fluid couplings.....	7
10-080* EN Characteristic starting curves.....	9
10-100* EN ROTOFLUID coupling selection diagram.....	12
10-141* EN Fluid couplings with delay fill chamber.....	8
10-180* EN ROTOFLUID coupling versions: ALFA and BETA.....	10
10-190* EN Instructions for replacement and variation of oil quantity.....	35
10-195* EN ROTOFLUID coupling special versions.....	36
45-015* EN ROTOFLUID ALFA for metric shaft K, SCF K, DCF K.....	14
45-017* EN ROTOFLUID ALFA for inches shaft KA, SCF KA, DCF KA.....	15
45-020* EN ROTOFLUID ALFA with flanged hub K-S, SCF K-S, DCF K-S.....	16
45-090* EN ROTOFLUID ALFA with elastic coupling K, SCF K, DCF K with RNV/FRNV e AB.....	17
45-091* EN ROTOFLUID ALFA with elastic element and brake disc K, SCF K, DCF K with RNPAV/FRNPAV e ADB.....	18
45-093* EN ROTOFLUID ALFA with elastic element and brake drum K, SCF K, DCF K with RND/FRND e AFF.....	19
45-113* EN ROTOFLUID ALFA with gear couplings RE / REU WAG-G/GU, SCF WAG-G/GU, DCF WAG-G/GU.....	20
45-120* EN ROTOFLUID ALFA with brake drum FPU / brake disc DPU WAG-GPU/GPUU, SCF WAG-GPU/GPUU, DCF WAG-GPU/GPUU21.....	21
45-215* EN ROTOFLUID BETA with and without delay fill chamber J, X, Z - SCF J, X, Z - DCF J, X, Z.....	26
45-281* EN ROTOFLUID ALFA with bell housing CKS.....	25
45-300* EN ROTOFLUID ALFA with disc coupling HBSX KLM-RH, KLM-L.....	22
45-305* EN ROTOFLUID ALFA with brake drum FFL / brake disc DFL KLM-LF/LLF, SCF KLM-LF/LLF, DCF KLM-LF/LLF.....	23
45-400* EN ROTOFLUID ALFA for reverse mounting NY-FB, NY-SCF-FB, NY DCF-FB.....	24
80-004* EN Electric-Thermal switch equipment type ET.....	29
80-022* EN Electronic device for overload control SCD.....	31
80-035* EN Protection Plugs.....	28
80-062* EN Device for speed and temperature control T09.....	30
90-005* EN Screw puller VE type - pulling off system SE type.....	32

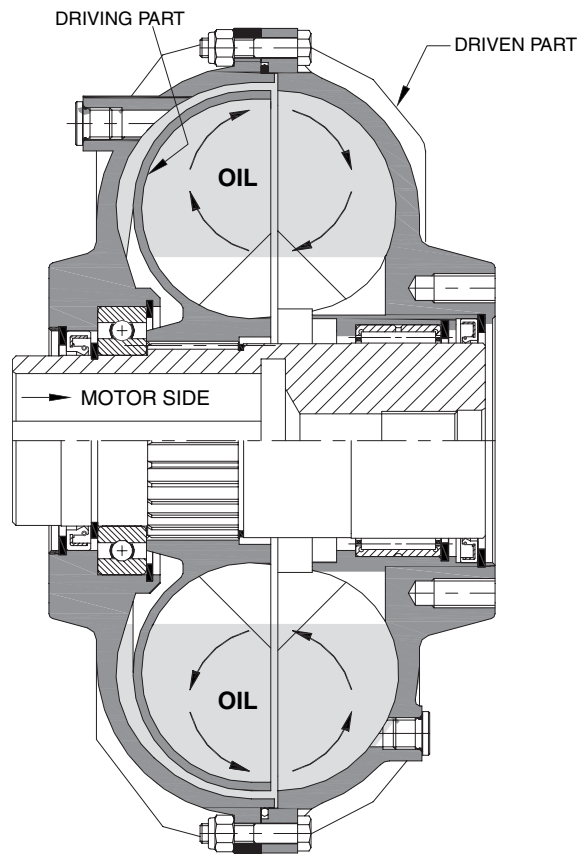

ROTOFLUID fluid coupling is designed to provide your plant with optimum reliability and durability. It is fitted between the motor (drive) and machine (driven component).

ROTOFLUID fluid coupling comprises basically two impellers, with radial blades, opposed to each other, one connected to the motor shaft and the other to the input shaft of the Driven Equipment or Machine. ROTOFLUID fluid coupling acts like a centrifugal clutch, by driving an impeller, the oil passing from the blades to the driven part, which acts as a driven impeller, transmits the power to the Equipment or Machine.

The oil, which fills the fluid coupling, transfers the torque and also lubricates moving parts.

Fluid couplings are the easiest and cheapest way of creating a perfectly Flexible Drive Train, because no mechanical parts are necessary between the motor and the Equipment or Machine being driven. Without mechanical parts, there is practically no wear.

Losses in the fluid coupling become power losses according to the following formula:

$$S\% = \frac{n_m - n_u}{n_m} \times 100$$

where:

n_m = motor speed (rpm)

n_u = output speed from the fluid coupling (rpm)

The elasticity of the fluid coupling solves problems of power peaks between electric motors and driven machines.

ADVANTAGES OF USING FLUID COUPLINGS

- easy start-up with gradual acceleration of the driven component
- automatic load speed adjustment on the basis of the synchronous speed of two or more motors
- the drive train is protected against overloads
- torsional vibrations are damped
- the torque transmitted complies with pre-set values
- direct on-line start electric motors can be used, without star-delta starters or slip-ring motors with rheostat

ADVANTAGES OF USING ROTOFUID FLUID COUPLINGS

- a large range of accessories
- interchangeable accessories on the basic cell
- the dimensions of the shaft-pulley system are perfectly suited to the needs of the drive train
- all fluid couplings that utilise a belt drive are fitted with ball bearings to guarantee above-standard radial loads
- all the fluid couplings used for horizontal applications are fitted with an elastic flexible coupling, which gives the advantage to the user of being able to replace the flexible element, by removing it radially from the coupling, without either disturbing the Motor or the Driven Equipment or Machine.

STANDARD MOUNTING

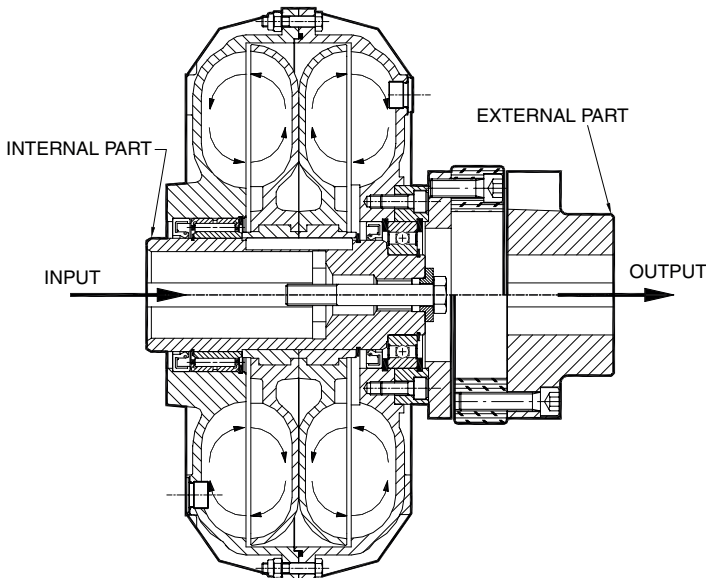

REVERSE MOUNTING

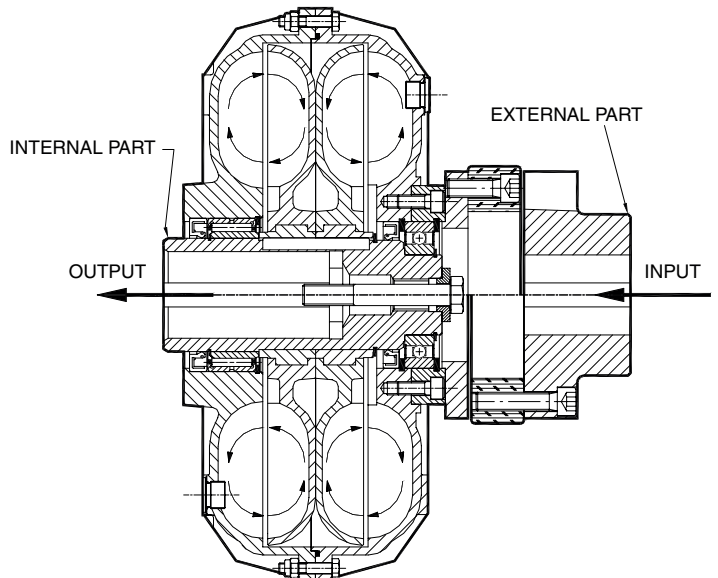

ADVANTAGES OF STANDARD MOUNTING

In **STANDARD** assemblies, the fluid coupling is mounted with the inner part connected to the motor shaft.

This is common for couplings with pulleys and in line application, providing the following benefits:

- standardisation of bores in compliance with UNEL MEC motors
- during start-up motor is less loaded due the low inertia of the inner part, operating speed is reach with reduced current peak
- in inline applications, where a brake is required, disc/drum is mounted directly on the reduction gear shaft without increasing the axial length of the coupling
- in couplings with delay fill chambers, start-up is smoother because the oil pass from the delay fill chamber into the circuit due to centrifugal force reducing the pick torque
- flexible element mounted on the fluid coupling is less stressed, because the torque is transmitted by the fluid and not with a direct connection to the motor.

ADVANTAGES OF REVERSE MOUNTING

In a **REVERSE** assembly, the fluid coupling is mounted with the outer part connected to the motor shaft.

This type of assembly is possible whenever the fluid coupling is mounted between motor and gear box.

For couplings with a V Pulley, the unit must be fitted to the driving shaft, pay attention between the driving and driven pulley ratio. In case of need consult WESTCAR srl.

This type of assembly has the following important advantages:

- higher heat dissipation, recommended in case of extended and frequent motor start-ups
- easier regulation and filling of the oil level in the coupling, since the external part can be rotated without moving the driven machine
- **IMPORTANT!** When the coupling is mounted with **THERMAL SWITCHING PIN**, even in case of stop of the driven side the function of the safety device is guarantee.

In the absence of special needs or requests, the coupling will be supplied in its **STANDARD** configuration.

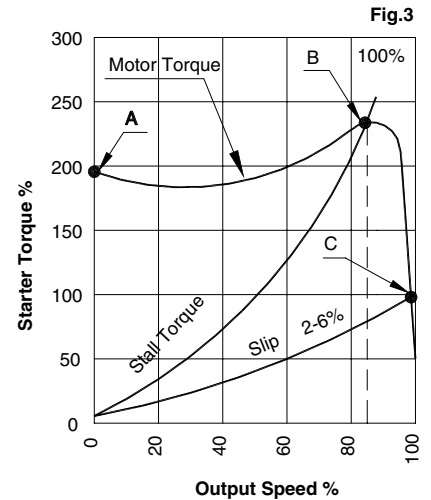
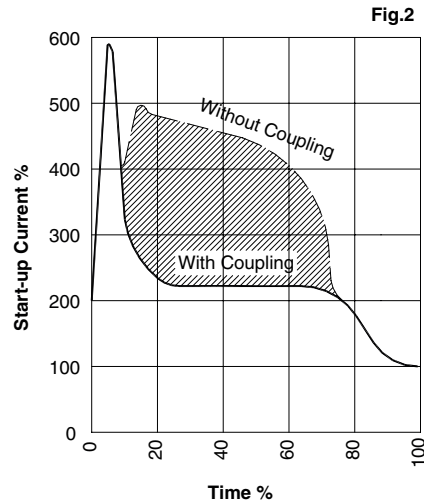
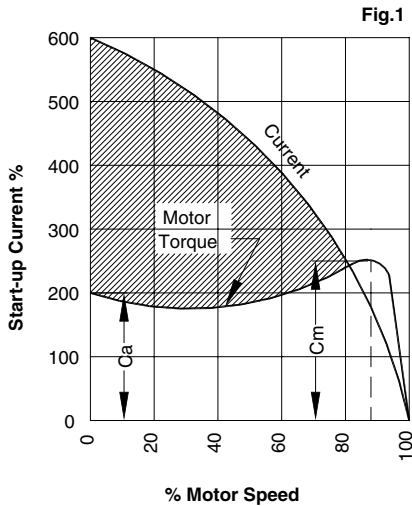

START-UP WITHOUT FLUID COUPLING

Figure 1 represents the typical start-up of an electric motor directly connected to the load. The dotted line represents the energy lost bringing the motor and load up to operating speed.

As can be seen, direct start-up has the following disadvantages:

- the difference between start-up torque (C_a) and the load requirement (C_m) is very low; the maximum torque is between 80%-85% of the operating speed
- the current absorbed during start-up may be up to 6 times the rated current, causing electrical overloads and higher costs, an increase in motor temperature and fewer possible start-ups.
- difficulty of application when a high starting torque is required.

START-UP WITH ROTOFUID FLUID COUPLING

Figure 2 compares the current absorbed by the electric motor starter with and without hydrodynamic coupling.

The first curve "Without coupling" is a start-up with direct connection in short-circuit. The second curve "With coupling" is the same start-up interposed with the hydrodynamic coupling. The crossed-out part represents the difference in energy used for the same start-up with and without hydrodynamic coupling.

In the first curve "Without coupling" the current reaches a peak of about six times the nominal and persists with high values up to the rated engine speed.

In the second curve "With coupling" the peak current remains high for only a few seconds (energy required to accelerate the motor rotor only) and goes down to acceptable values for the time necessary to bring the machine to scheme.

When the hydrodynamic coupling ROTOFUID is interposed between the electric motor and the driven machine, the motor can start-up in short circuit.

CHARACTERISTIC CURVES FOR START-UP WITH FLUID COUPLING

Figure 3 shows a characteristic torque curve for an electric motor, the stall curve of the fluid coupling and the slip curve at operating speed. The fluid coupling allows the motor to reach 80-85% speed in a few seconds (shift from point A to point B) where it meets the stall curve of the fluid coupling (slip=100%), the point of maximum motor torque.

Point C is the point of functioning of the fluid coupling after the motor has reached operating speed.

The use of a fluid coupling with a delay fill chamber limits maximum torque during start-up, without prejudicing slipping in normal functioning. This allows the motor to quickly increase speed [revs] without hitting the resistant torque (as if it started unloaded).

A fluid coupling with a delay fill feature is fitted with additional chamber in order to reduce the quantity of oil in the working circuit (see Fig.1). The chamber is in contact with the circuit via calibrated nozzles, which can be set as required (see Fig.2). The variation in the calibrated nozzle holes changes the time it takes for the oil in the chamber to reach the working circuit, thereby, increasing or decreasing start-up time for the driven machine.

When all the oil has flowed from the chamber into the circuit, the fluid coupling reaches the rated speed, transmitting the required torque with minimum slippage (see Fig.3).

Fluid couplings may be fitted with either a single or double delay fill chamber.

With a single delay fill chamber, Ca/Cn torque limitation varies from 180% to 150%, adjusting the quantity of oil.

With a double delay fill chamber, Ca/Cn torque limitation varies from 150% to 120%, adjusting the quantity of oil.

The advantages of delay fill chambers are enhanced as the power requirement rises.

SCF and DCF delay fill chambers are available from size 30 to size 95P.

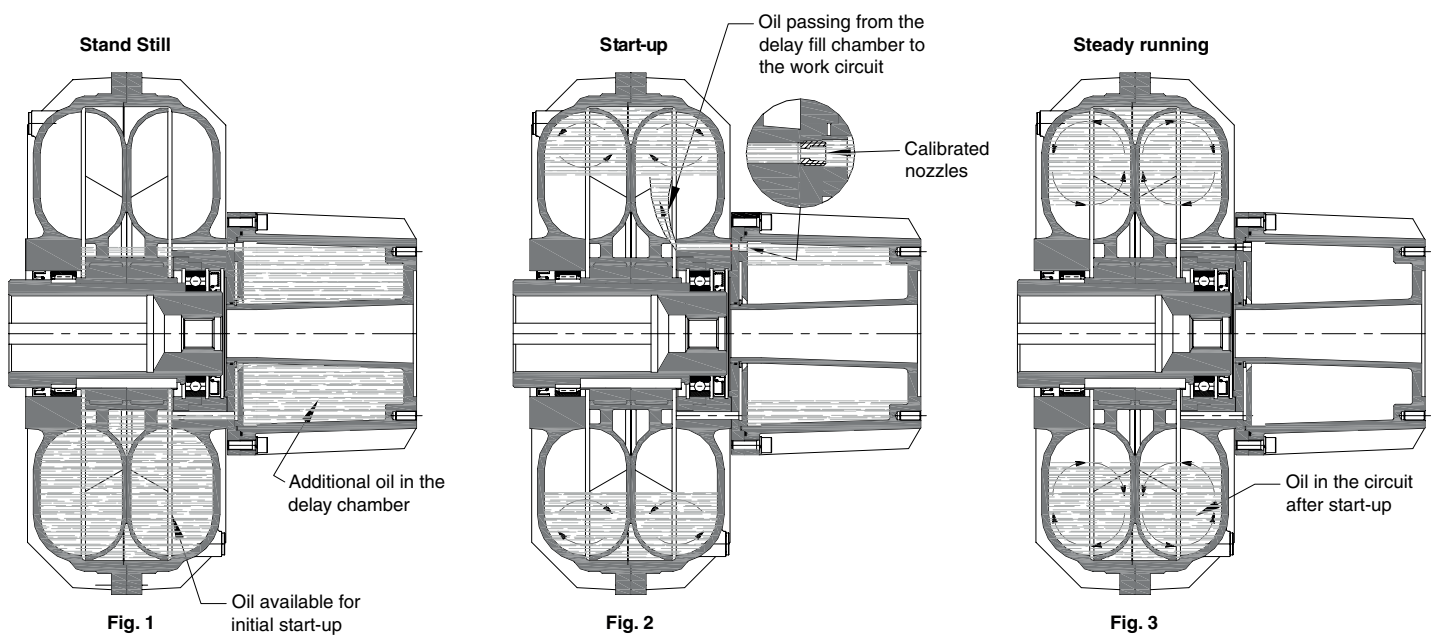

ADVANTAGES

- Low energy loss even where inertia is high
- Start-up time can be adjusted
- Start-up torque is limited to pre-set values without affecting slip
- Limitation of start-up current prolongs the life of the motor
- For controls with several drives the coupling automatically adjusts the load speed on the basis of synchronous speed
- More start-ups per hour

The ROTOFLUID SCF/DCF peculiarities are more evident comparing the curve of the ROTOFLUID coupling without delay chamber.

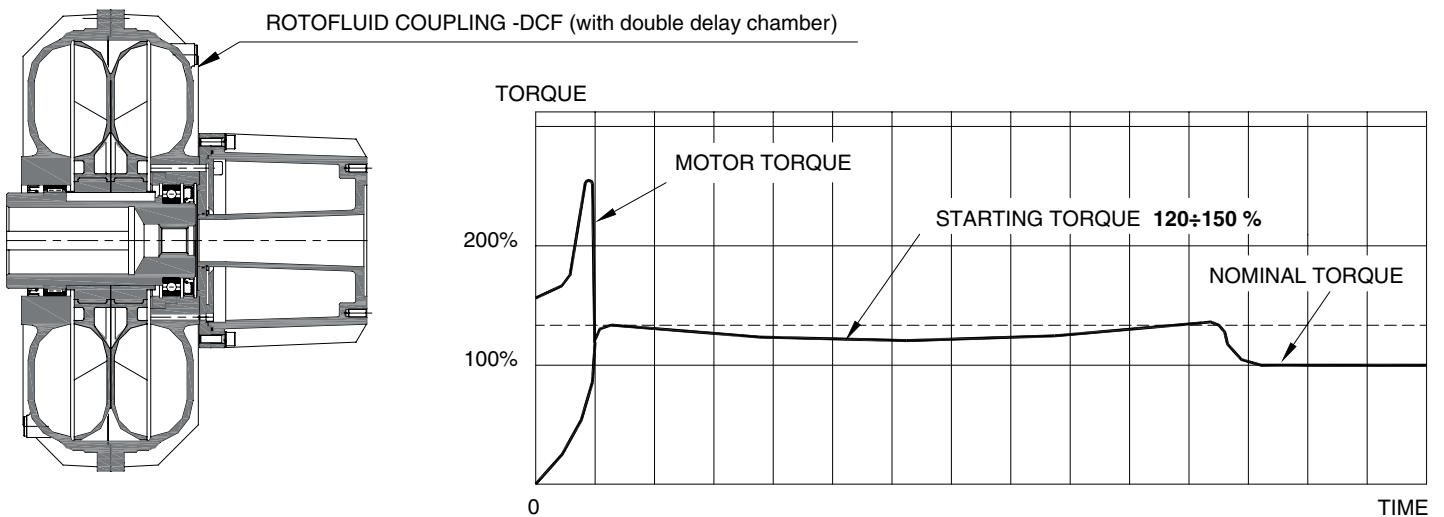
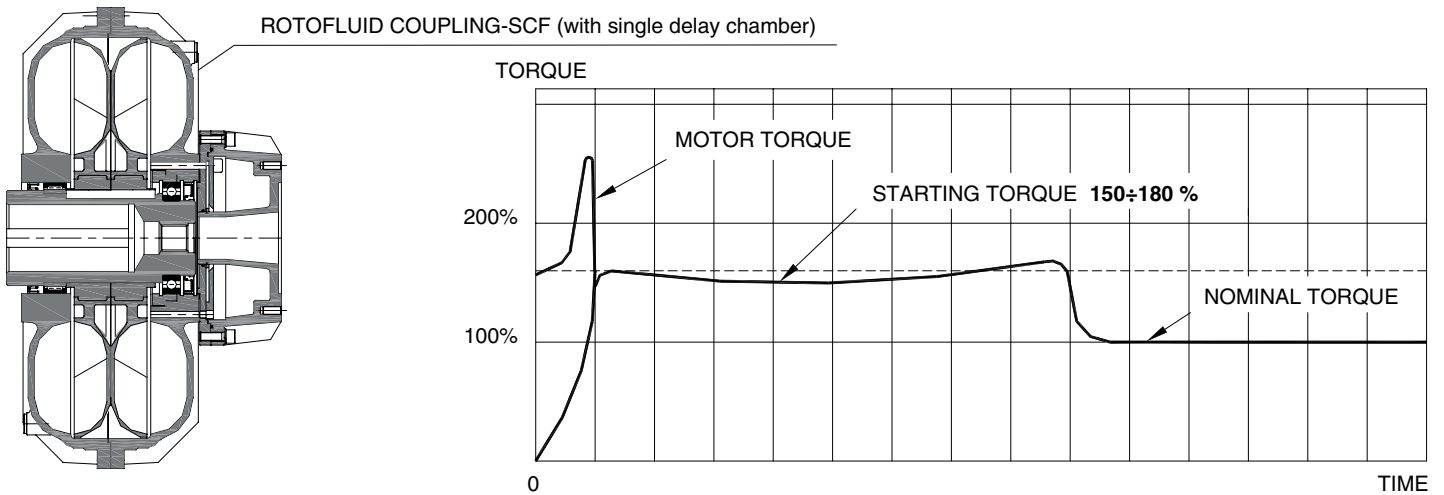
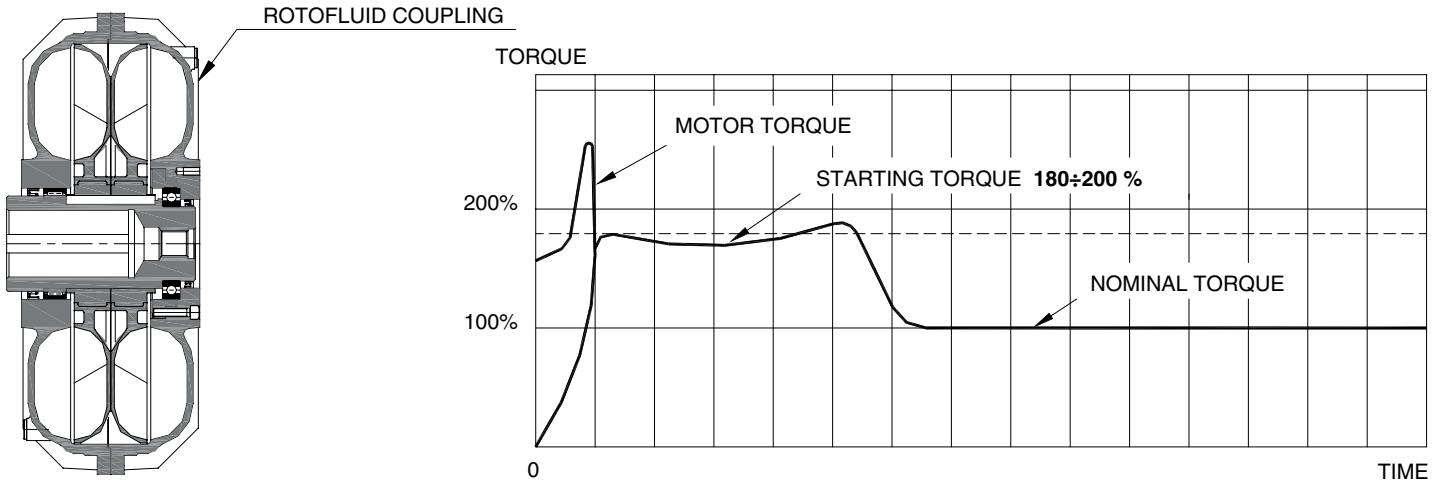

ROTOFLUID COUPLING ALFA

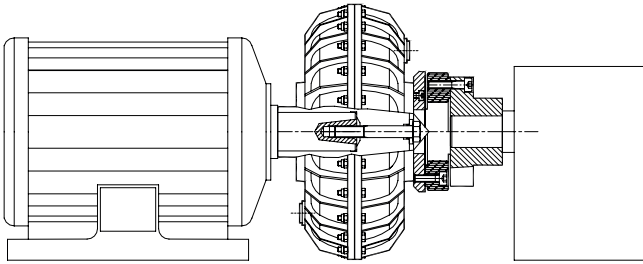

ROTOFLUID COUPLING BETA

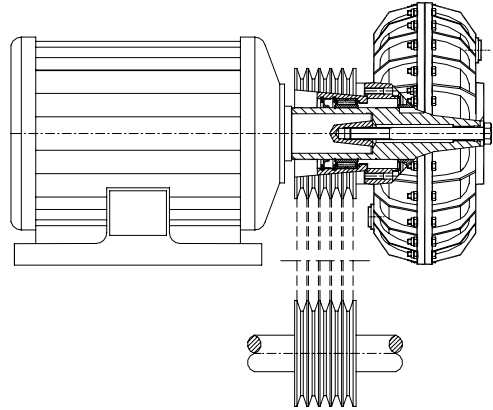

ROTOFLUID COUPLINGS **ALFA** are used for in-line transmission between equipment.

ALFA couplings can be supplied with several accessories that allow easy installations and maintenance.

ROTOFLUID COUPLINGS **BETA** are used for pulleys transmission equipment between parallel shafts.

These couplings are available also with Delay Fill Chambers.

ALFA

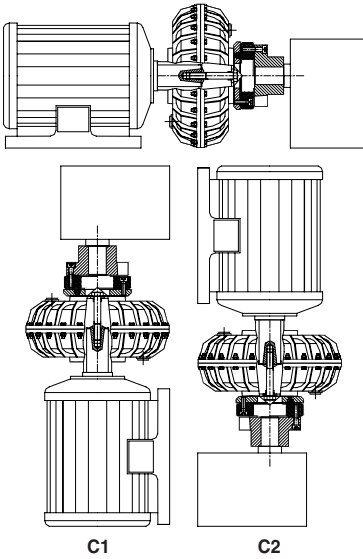

BETA

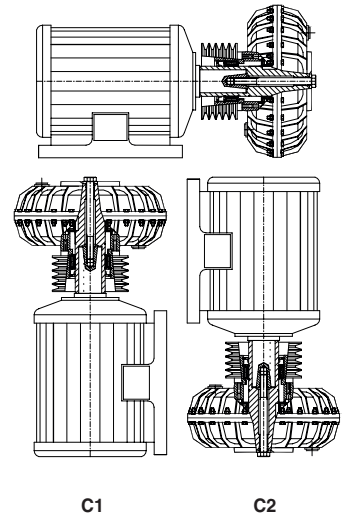

INSTALLATION OPTIONS

ROTOFLUID couplings **ALFA** and **BETA** can be horizontally or vertically mounted
In case of Vertical Installation (C1 or C2) contact WESTCAR

ALFA and **BETA** couplings are supplied with fixing screw.

IMPORTANT

COUPLING WITH DELAY CHAMBER CORRECT INSTALLATION

HORIZONTAL SHAFT

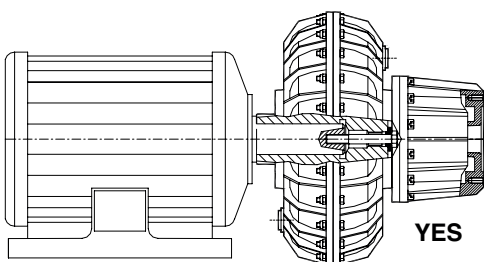

VERTICAL SHAFT WITH
DOWNWARD DELAY CHAMBER

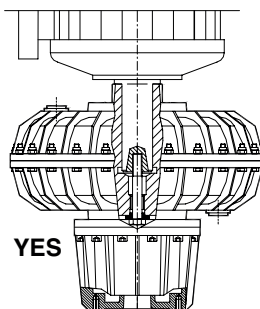

VERTICAL SHAFT WITH UPWARD
DELAY CHAMBER

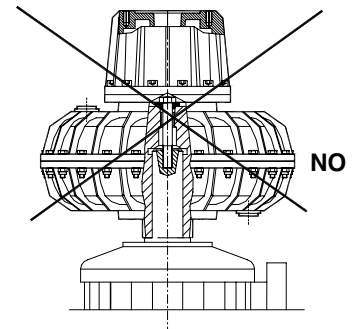

ROTOFLUID ALFA without accessories

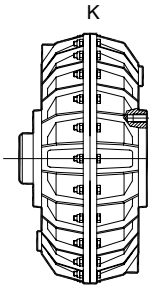

K
PAG. 14

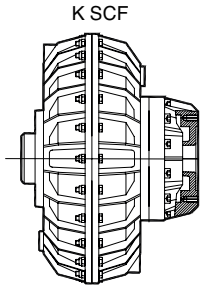

K SCF
PAG. 14

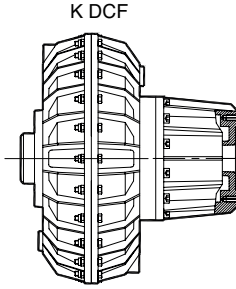

K DCF
PAG. 14

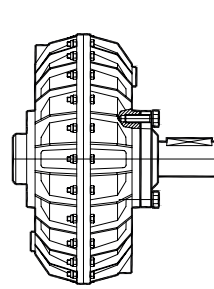

ROTOFLUID ALFA K-S
PAG. 16

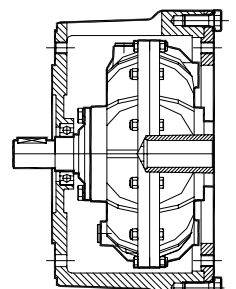

ROTOFLUID ALFA CKS
PAG. 25

ROTOFLUID ALFA K with elastic coupling

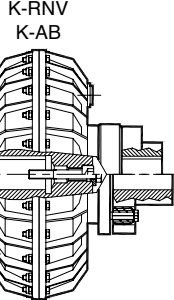

K-RNV
K-AB
PAG. 17

ROTOFLUID ALFA K with elastic coupling and Brake Disc

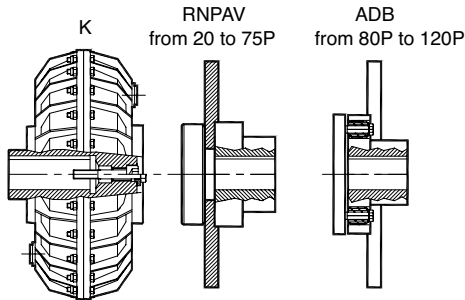

K
PAG. 18

RNPV
from 20 to 75P

ADB
from 80P to 120P

ROTOFLUID ALFA K with elastic coupling and Brake Drum

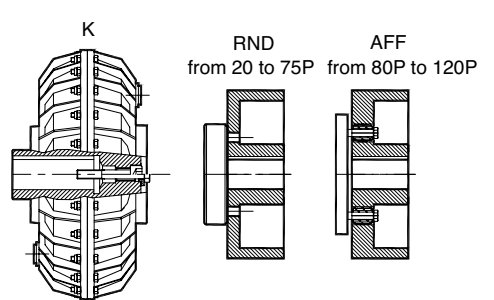

K
PAG. 19

RND
from 20 to 75P

AFF
from 80P to 120P

ALFA WAG-G

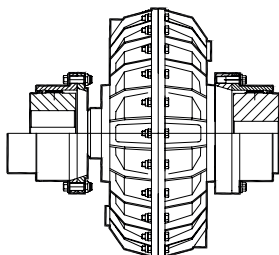

PAG. 20

ALFA WAG-GU

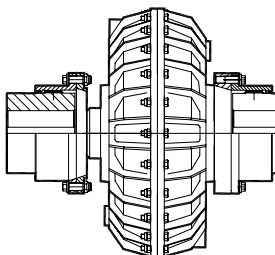

PAG. 20

ALFA WAG-GPU

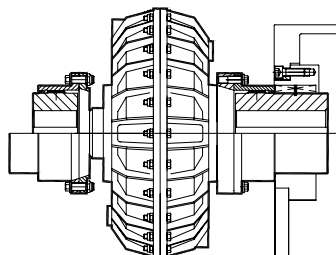

ALFA WAG-GPUU
PAG. 21

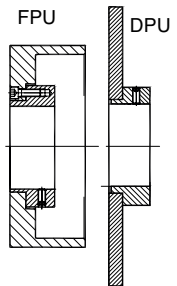

ALFA KLM-RH

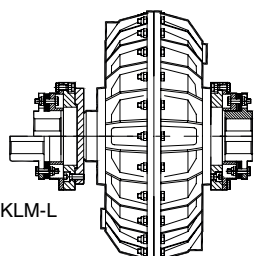

PAG. 22

ALFA KLM-L

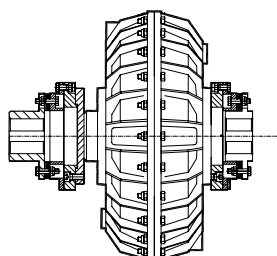

PAG. 22

ALFA KLM-LF

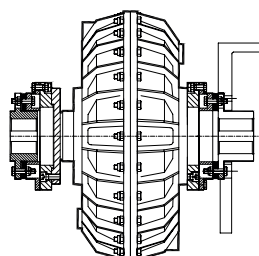

PAG. 23

ALFA KLM-LLF

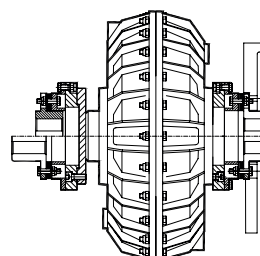

PAG. 23

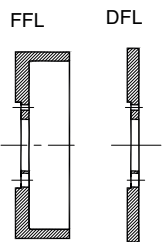

ALFA NY-FB

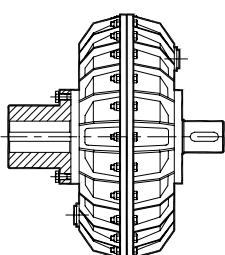

PAG. 24

BETA J

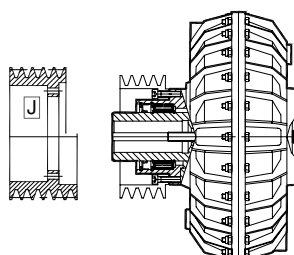

PAG. 26

BETA X

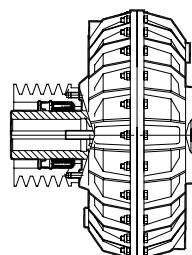

PAG. 26

BETA Z

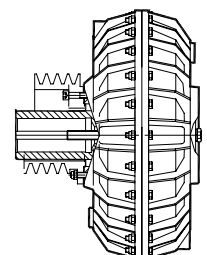

PAG. 26

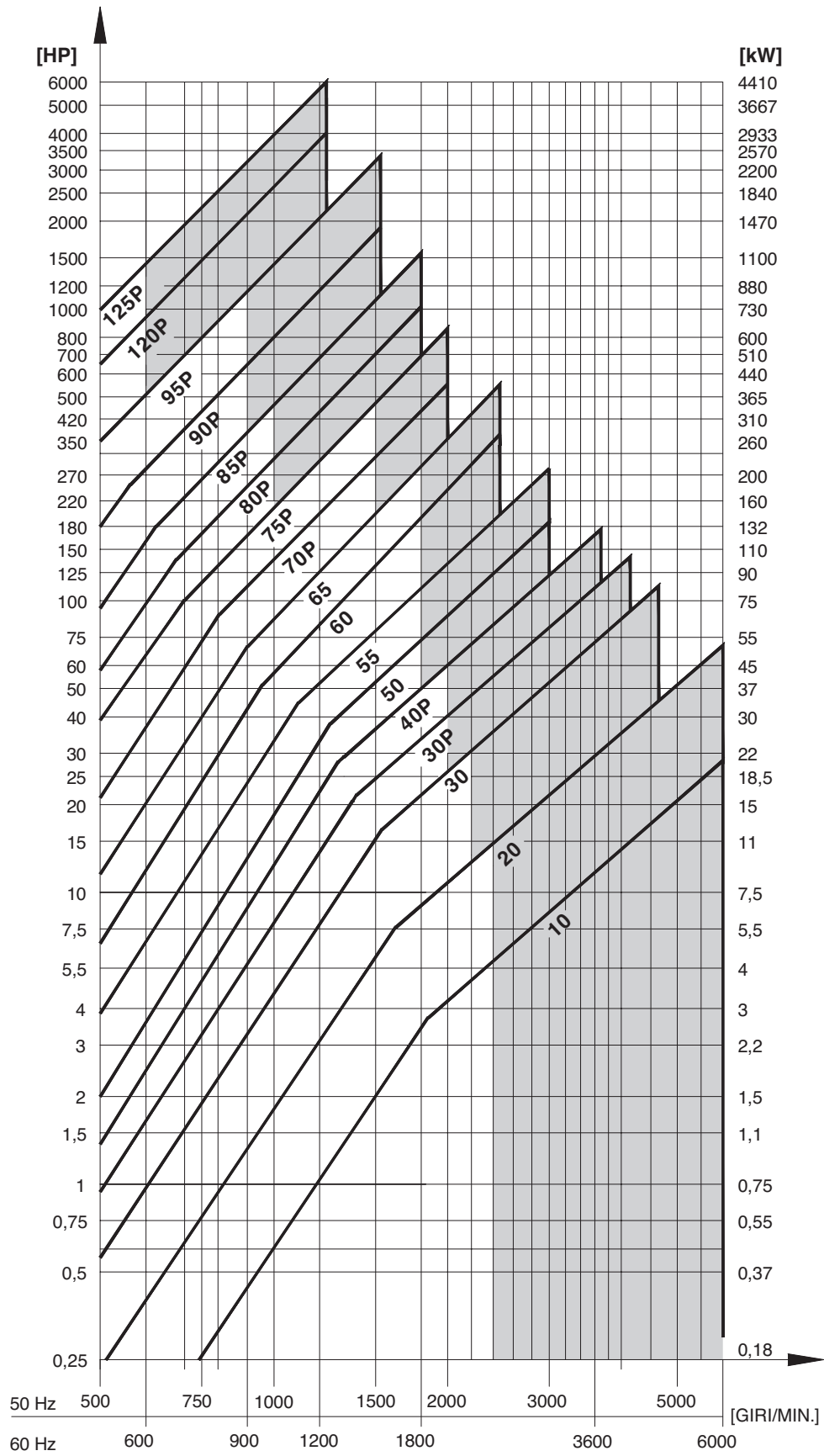

Select coupling size on input power and speed
 The curves show limit capacity of couplings
 If the selection point falls on or close to the max capacity limit line of a given coupling size, please contact WESTCAR
 For use at rpm included in the marked ranges, balancing with oil is required

STANDARD ELECTRIC MOTORS		Motor speed 50 Hz											Motor speed 60 Hz						
		8 poles 750 rpm			6 poles 1000 rpm			4 poles 1500 rpm			2 poles 3000 rpm		6 poles 1200 rpm			4 poles 1800 rpm			
Type	Ø Shaft	kW	HP	Coupling	kW	HP	Coupling	kW	HP	Coupling	kW	HP	Coupling	kW	HP	Coupling	kW	HP	Coupling
71	14	-	-	-	0,25	0,33	10	0,25	0,33	10	0,37	0,5	10	0,25	0,35	10	0,25	0,35	10
80	19	-	-	-	0,37	0,5		0,37	0,5		0,55	0,75		0,75	1		0,55	0,75	
90S	24	-	-	-	0,75	1	20	0,75	1	20	1,1	1,5	10	0,75	1	20	0,75	1	20
90L	24	0,55	0,75	20	1,1	1,5		1,1	1,5		1,5	2		1,5	2		1,5	2	
100L	28	1,1	1,5	30	1,5	2	30	2,2	3	20	2,2	3	20	1,5	2	20	1,5	2	20
112M	28	1,5	2	30P	2,2	3		3	4		3	4		3	4		3	4	
132	38	-	-	30P	3	4	30P	5,5	7,5	30	5,5	7,5	20	3	4	30	3	4	20
132M	38	3	4	40P	4	5,5		7,5	10		7,5	10		-	-		3	4	
160M	42	4	5,5	50	7,5	10	40P	11	15	30P	11	15	30	7,5	10	30P	11	15	30
160L	42	7,5	10	55	11	15		15	20		15	20		18,5	25		15	20	
180M	48	-	-	55	-	-	50	18,5	25	40P	18,5	25	30	-	-	40P	18,5	25	30P
180L	48	11	15	60	15	20		22	30		22	30		-	-		15	20	
200L	55	15	20	60	18,5	25	55	30	40	50	30	40	50	22	30	50	22	30	40P
225S	60	18,5	25	65	-	-		37	50		37	50		-	-		37	50	
225M	55 60	- 22	- 30	65	-	-	60	-	-	55	45	60	40P	-	-	55	-	-	50
250M	60 65	- 30	- 40	65	37	50		-	55		55	75		55	75		-	-	
280S	65 75	- 37	- 50	70P	-	-	65	-	-	60	75	100	50	-	-	60	-	-	60
280M	65 75	45	60		-	45		60	-		75	100		75	100		-	-	
315S	65 80	- 55	- 75	70P	-	-	70P	-	-	65	110	150	55	-	-	65	-	-	60
315M	65	-	-		-	-		-	-		-	-		132	180		110	150	
355S	80 100	- 132	- 180	80P	90	125	75P	132	180	70P	132	180	75P	160	220	75P	160	220	70P
355M	80 100	- 160	- 220		110	150		132	180		160	220		200	270		-	-	
				80P	160	220	80P	250	340	75P	250	340	75P	250	340	75P	250	340	75P
				85P	-	-	85P	-	-	75P	-	-	75P	-	-	75P	-	-	75P
				90P	200	270	85P	315	430		315	430			315	430	315	430	75P
				90P	250	340													
NON STANDARD ELECTRIC MOTORS For max. power transmitted		330	450	90P	370	500	85P	510	700	80P				310	420	80P	440	600	75P
		600	800	95P	600	800	90P	810	1100	85P				440	600	85P	700	950	80P
		800	1100	120P	1000	1360	95P	1300	1740	90P				800	1100	90P	1000	1360	85P
		1000	1360	125P	2000	2720	120P	2300	3100	95P				1380	1880	95P			
					3300	4500	125P	-	-	-				2580	3500	120P			
													4200	5710	125P				

• For couplings at 3000 rpm, ask for balancing required

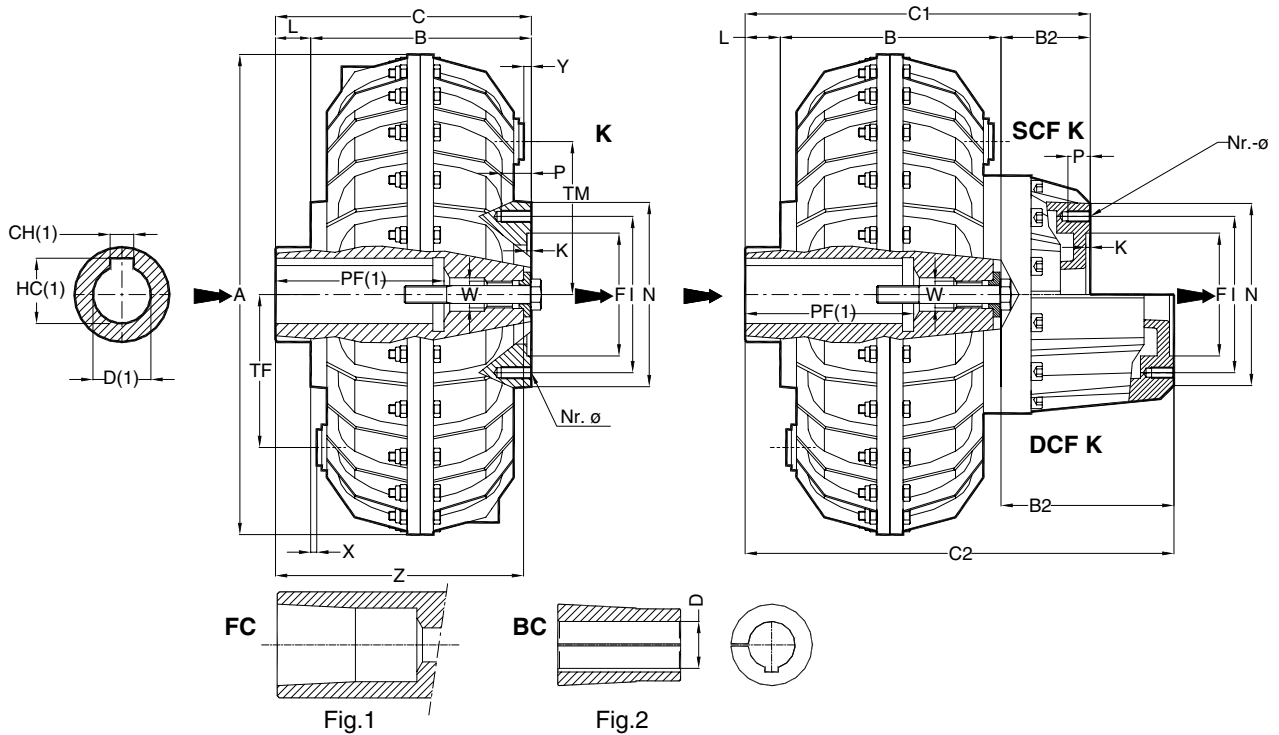

NOTES: (1) for bore and keyway dimensions see sheet 10-019E / (2) the arrows ► indicate input and output

ROTOFLUID SIZE	Dimensions in mm														K			SCF K				DCF K					
	Bore D	A	B	K	I	L	N	Nr.ø	P	TF TM	W	X	Y	Z	Type	mm		kg*	mm		kg*	mm		kg*			
																C	F ^{H7}		B2	C1		F ^{H7}	B2		C2	F ^{H7}	W.
10	19-24	193	88	4	60	10	75	6-M6	12	66	M10	0,5	0	94	K1	98	47	4	--	--	--	--	--	--	--	--	
20	24-28	230	115		78		94	6-M8	12	80	M14	2	7	120	K1	125	62	6	--	--	--	--	--	--	--	--	--
30	□FC	290	150		100	12	114	8-M8	16	110	M24	9	9	157,5	K2	162	72	13,2	K2	55	217	72	15,6	K2	95	257	72
30P	□FC	327	183	125	15	145	8-M10	22	130	6		6	6	6	K2	198	90	22	K2	58	256	90	23,4	K2	130	328	90
40P	□FC	338								154	140	25	165	150	20	176,5	K2	179	110	30	K2	80	259	35,8	K2	155	334
50	□FC	430	196	4,5	160	20	185	8-M10	205	M30	6	20	192	K2	192	125	46	K2	90	282	125	54,4	K2	170	362	58	
55	□FC		172											15	6	208,5	K2	211	40	K2	80	291	110	45,8	K2	155	366
60	□FC 75	520	220	4	195	20	225	8-M16	24	265	M36	15	234	K2N	240	86	K2N	350	150	99	K2N	225	465	150	106		
65	□FC 75-80		172										20	185	205	M30	6	240	K2	240	66	K2	90	330	74,4	K2	170
70P	80-90 100	640	190	4	230	44	60	270	8-M18	28	325	20	264	K2N	270	180	K2N	388	160	196	K2N	218	488	160	208		
75P	80-90 100		245										20	35	265	M36	0	254	K2N	265	117	K2N	375	390	135	K2N	490
80P	Max.110 Max.125**	810	226	5	506	20	120	160	16-M20	32	416	35	264	K2N	270	160	K2N	388	160	196	K2N	218	488	160	208		
85P	Max.125 Max.130		300										40	270	28	325	0	264	K2N	270	160	K2N	388	404	160	K2N	488
90P	Max.130 Max.140** Max.160***	1000	344	5	506	13	120	160	16-M20	32	416	35	343	K2	364	350	K2	424	445	302	K2	200	504	445	317		
95P	Max.130 Max.140** Max.160***		466										13	120	160	16-M20	32	416	35	420	479	445	505	K2	479	505	K2
120P	Max.190	1300	449	7	310	7	570		36	430		30	419	K2	456	220	1800	--	--	--	--	--	748	220	--		

* Weight with oil - ** Bore depth PF=210 - *** Bore depth PF=250

DIMENSIONS ARE NOT BINDING

• Supplied with OVERSIZED CHAMBER SCFM or DCFM

□ Couplings with conical bore FC are supplied with Taper Bush BC and fixing screw (Fig. 1 and 2)
In case of mounting on shafts without shoulder contact WESTCAR

TAPER BUSH BC WITH FIXING SCREW							
COUPLING SIZE	Type	Standard D Bore					Max D Bore
30/30P	3BC	38	42	48	-	-	48
40P	4BC	38	42	48	50	-	50
50 - 55	5BC	-	42	48	55	60	65
60 - 65	6BC	-	-	48	55	60	70

■ Taper Bushes are supplied without keyway

Example of order of a coupling with taper bush: ALFA 55 K2 FC + 55BC L15 D=60

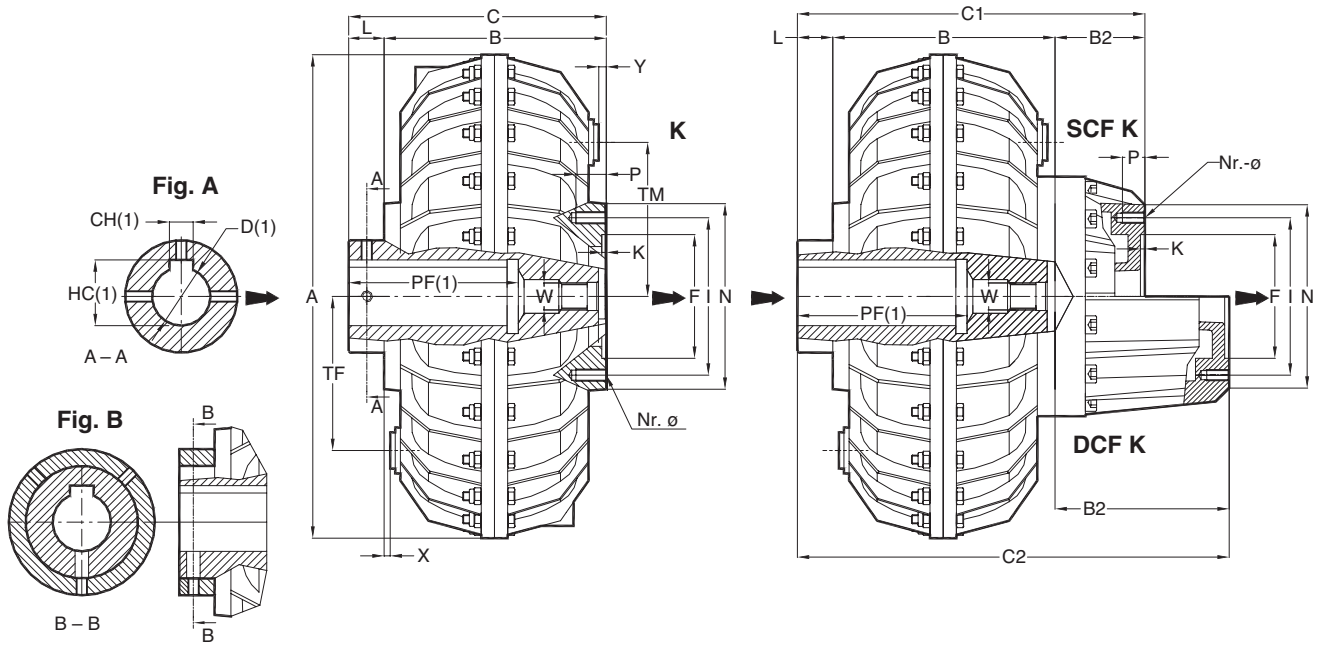

NOTES: (1) the arrows ► indicate input and output

ROTOFLUID SIZE	inches	Dimensions in mm														K			SCF K			DCF K								
		Cyl. bore D	Fig.	A	B	F ^{H7}	K	I	L	N	Nr.ø	P	TF TM	W	X	Y	PF	Type	C	kg*	Type	mm		kg*	Type	mm		kg*		
																						B2	C1			B2	C2		W.	
10 KA	0,875 1,125	A B	193	88	47	4	60	10 25,4	75	6-M6	12	66	M10	0,5	0	57,15 69,85	KA	98 113,4	4	--	--	--	--	--	--	--	--	--	--	--
20 KA	1,125 1,375	A B	230	115	52		78	10 25,4	94		8-M8	16	110	M14	2	7	69,85 85,72	KA	125 140,4	6	--	--	--	--	--	--	--	--	--	--
30 KA	1,625 1,875	A B	290	150	72	4,5	100	12 40	114	8-M8		16	110	M24	9	9	101,6 117,47	KA	162 190	13,2	KA	55	217 245	15,6	KA	95	257 285	16,2		
30P KA	1,625 1,875	A B	327		100		12 40	6			6							85,72	162 190	21	KA		217 245	23,4	KA		257 285	24		
40P KA	1,625 1,875 2,125	A	338	183	90	4,5	125	15	145	8-M10	22	130	M24	29	16	101,6 133,35	KA	198	22	KA	58	256	25,7	KA	130	328	27,2			
50 KA	1,875 2,125 2,375	A A B	430	154	110		140	25 25 32	165							22	150	6	20	117,47 133,35 149,22	KA	179 179 186	30	KA	80	259 259 266	35,8	KA	155	334 334 341
55 KA	2,125 2,375 2,875	A B B				140	15 20 54	6		6	133,35 149,22 184,15	KA	211 216 250	40	KA															
60 KA	2,375 2,875 3,375	A A B	520	172	125	4,5	160	20 57 108	185	8-M10	22	205	M30	6	20	149,22 184,15 215,9	KA	192 229 280	46,5 46,5 50,5	KA	90	282 319 370	54,4 56 66	KA	170	362 399 450	57,5 58,5 68,5			
65 KA	2,375 2,875 3,875	A A B					160	20 20 61								6	6	149,22 184,15 215,9	KA	240 240 281	66	KA	330 330 371	74,4	KA	410 410 451	78			
70P KA	2,875 3,375 3,875	A	640	190	150	4	195	50 90 126	225	8-M16	24	265	M36	15	0	184,15 215,9 250,82	KA	240 280 316	86	KA	110	350 390 426	99	KA	225	465 505 541	106			
-75P KA	3,375 3,875	A B					195	40 76								0	0	215,9 250,82	KA	285 321	117	KA	395 431	135	KA	510 546	147			
80P KA	3,375 3,875 4,750	A	810	226	160	5	230	44 44 76	270	8-M18	28	325	M36	15	0	215,9 250,82 250,82	KA	270 270 302	180	KA	118	388 388 420	196	KA	218	488 488 520	208			
-85P KA	3,875 4,750	A					230	40								0	0	250,82	KA	340	252	KA	458	280	KA	558	300			
90P KA	3,875 4,750 5,250	A	1000	344	445	5	506	40	550	16-M20	32	416	M36	35	0	250,82	KA	384	350	KA	120	504	302	KA	200	584	317			
95P KA	3,875 4,750 5,250	A					506	550								32	416	35	250,82	KA	506	505	KA	626	545	KA	706	560		

* Weight with oil • Supplied with OVERSIZED CHAMBER SCFM or DCFM ■ Reduced Dimension HC

DIMENSIONS ARE NOT BINDING

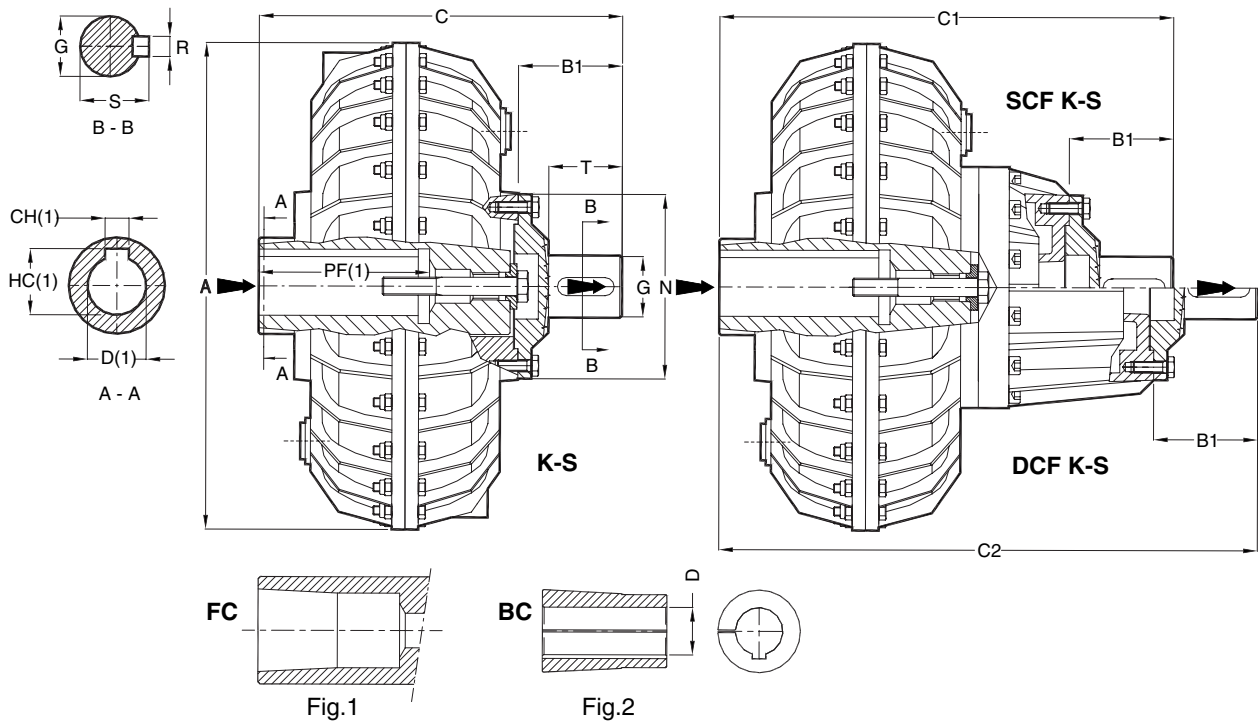

NOTES: (1) for bore and keyway dimensions see sheet 10-019E / (2) the arrows ► indicate input and output

ROTOFLUID SIZE	Dimensions in mm								K-S		SCF K-S			DCF K-S			
	Foro D	A	B1	G h7	N	R	S	T	Type	mm	kg*	Type	mm	kg*	Type	mm	kg*
									C	Weight	C1	Weight	C2	Weight			
10	19-24	193	35	19	75	6	21,5	25	K1-S1	133	4,3	--	--	--	--	--	--
20	24-28	230	44	24	94	8	27	32	K1-S2	169	6,6	--	--	--	--	--	--
30	FC	290	63	38	114	10	41	45	K2-S3	225	14,3	K2-S3	280	16,7	K2-S3	320	17,3
30P	FC	327															
40P	FC	338	76	48	145	14	51,5	55	K2-S4	274	24,2	K2-S4	332	27,9	K2-S4	404	29,4
50	FC	430	92	55	165	16	59	65	K2-S5	271	33,2	K2-S5	351	39	K2-S5	426	41,2
55	FC								K2-S5	303	43,2	K2-S5	383	49	K2-S6	458	51,2
60	FC 75	520	110	60	185	18	64	80	K2-S6	302	50,6	K2-S6	392	59	K2-S6	472	62,6
65	FC 75-80								K2-S6	350	70,6	K2-S6	440	79	K2-S6	520	82,6
70P	80-90 100	640	122	70	225	20	74,5	90	K2N-S7	362	95	K2N-S6	472	108	K2N-S7	587	115
75P	80-90 100								K3N-S7	402	126	K2N-S7	497	144	K2N-S7	612	156
80P	Max.110 Max.125**	810	145	80	270	22	85	110	K2N-S8	415	198	K2N-S8	533	214	K2N-S8	633	226
85P	Max.125 Max.130								K3N-S8	431	270	K2N-S8	603	298	K2N-S8	703	318
90P	Max.130 Max.140** Max.160***	1000	220	110	550	28	116	180	K2-S9	584	416	K2-S9	644	368	K2-S9	724	383
95P	Max.130 Max.140** Max.160***								K3-S9	684	456	K3-S9	744	408	K3-S9	824	423
									K5-S9	724	476	K5-S9	784	428	K5-S9	864	443
									K2-S9	669	586	K2-S9	819	626	K2-S9	899	641
									K3-S9	806	636	K3-S9	926	676	K3-S9	1006	691
									K5-S9	846	656	K5-S9	966	696	K5-S9	1046	711
120P	Max.190	1300	290	180		45	190	250	K2-S12	746	1900	--	--	--	--	--	--

* Weight with oil - ** Bore depth PF=210 - *** Bore depth PF=250

DIMENSIONS ARE NOT BINDING

- Supplied with OVERSIZED CHAMBER SCFM or DCFM
- Couplings with conical bore FC are supplied with Taper Bush BC and fixing screw (Fig. 1 and 2)
In case of mounting on shafts without shoulder contact WESTCAR

Example of order of a coupling with taper bush: ALFA 55 K2 FC + 55BC L15 D=60 + S5

TAPER BUSH BC WITH FIXING SCREW								
COUPLING SIZE	Type	Standard D Bore						Max D Bore
30/30P	3BC	38	42	48	-	-	-	48
40P	4BC	38	42	48	50	-	-	50
50 - 55	5BC	-	42	48	55	60	65	65
60 - 65	6BC	-	-	48	55	60	65	70

■ Taper Bushes are supplied without keyway

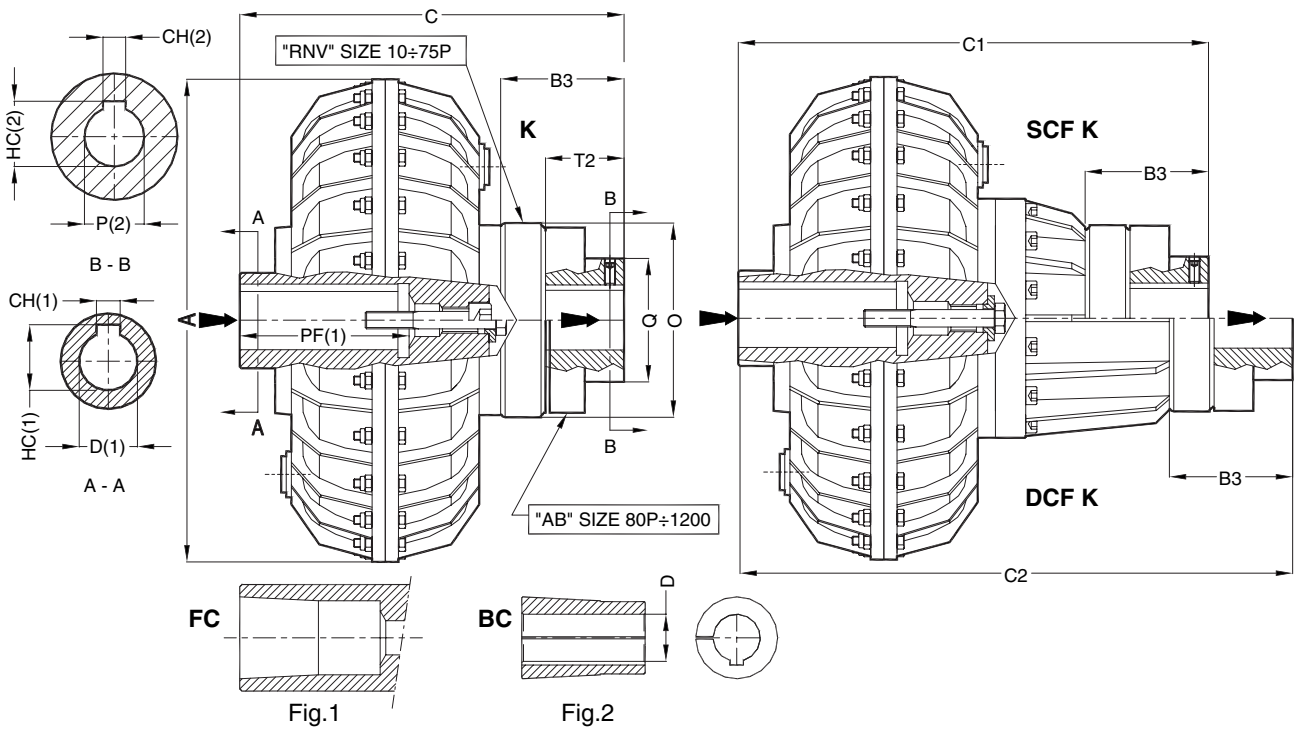

NOTES: (1) for bore and keyway dimensions see sheet 10-019E / (2) upon request: bore P finished / (3) the arrows ► indicate input and output

ROTOFLUID SIZE	Dimensions in mm								K with EL. Coupling			SCF K with EL. Coupling			DCF K with EL. Coupling			ELASTIC COUPLING
	Bore D	A	B3	O	P Max.	Q	T2	Type	mm	kg*	Type	mm	kg*	Type	mm	kg*		
									C	Weight		C1	Weight		C2	Weight		
10	19-24	193	48	88	28	45	30	K1	146	4,7	--	--	--	--	--	--	RVN-1	
20	24-28	230	67	110	38	56	45	K1	192	7,6	--	--	--	--	--	--	RVN-2	
30	FC	290	85	140	48	68	55	K02	247	16,2	K02	302	18,6	K02	342	19,2	RVN-3	
30P	FC	327						K02			24			K02				26,4
40P	FC	338	94	176	60	91	60	K02	292	26,6	K02	350	30,3	K02	422	31,8	RVN-4	
50	FC	430	108	194	70	106	70	K02	287	37	K02	367	42,8	K02	442	45	RVN-5	
55	FC							K02	319	47	K02	399	52,8	K02	474	55		
60	FC 75	520	122	216	80	121	80	K02	314	56,3	K02	404	64,7	K02	484	68,3	RVN-6	
65	FC 75-80							K02	362	76,3	K02	452	84,7	K02	532	88,3		
70P	80-90 100	640	138	266	100	146	90	K2N	378	101,5	K2N	488	114,5	K2N	603	121,5	RVN-7	
	100							K3N	418		K3N	528		K3N	643			
75P	80-90 100	640	194	309	110	156	110	K2N	459	154	--	--	--	--	--	--	FRNV-8	
	100		K3N					474	K2M		541	163,7	K2M	656	175,7	K3M		671
80P	Max.110 Max.125**	810	196	330	110	170	140	K2N	466	238,5	K2N		584	254,5		K2N	684	700
	100		K3N					482	K3N		600	K3N	700					
85P	Max.125 Max.130	1000	226	400	155	236	170	K2N	566	363	K2N	684	391	K2N	784	411	AB-8M	
	100		K3N					684	K3N		784							
90P	Max.130 Max.140** Max.160***	1000	318	550	180	290	250	K2	682	604	K2	742	556	K2	882	571	AB-9	
	K3							782	K3		842	K3		982				
	K5							822	K5		882	K5		1022				
	K5							822	K5		882	K5		1022				
95P	Max.130 Max.140** Max.160***	1000	318	550	180	290	250	K2	797	759	K2	917	799	K2	997	814	AB-9	
	K3							904	K3		1024	K3		1104				
	K5							944	K5		1064	K5		1144				
	K5							944	K5		1064	K5		1144				
120P	Max. 190	1300	318	550	180	290	250	K2	774	2050	--	--	--	--	--	--	AB-9/12	

* Weight with oil - ** Bore depth PF=210 - *** Bore depth PF=250

DIMENSIONS ARE NOT BINDING

• Supplied with OVERSIZED CHAMBER SCFM or DCFM

□ Couplings with conical bore FC are supplied with Taper Bush BC and fixing screw (Fig. 1 and 2)
In case of mounting on shafts without shoulder contact WESTCAR

Example of order of a coupling with taper bush: ALFA 55 K02 FC + 55BC L15 D=60 + RVN5 P=48

TAPER BUSH BC WITH FIXING SCREW								
COUPLING SIZE	Type	Standard D Bore						Max D Bore
30/30P	3BC	38	42	48	-	-	-	48
40P	4BC	38	42	48	50	-	-	50
50 - 55	5BC	-	42	48	55	60	65	65
60 - 65	6BC	-	-	48	55	60	65	70

■ Taper Bushes are supplied without keyway

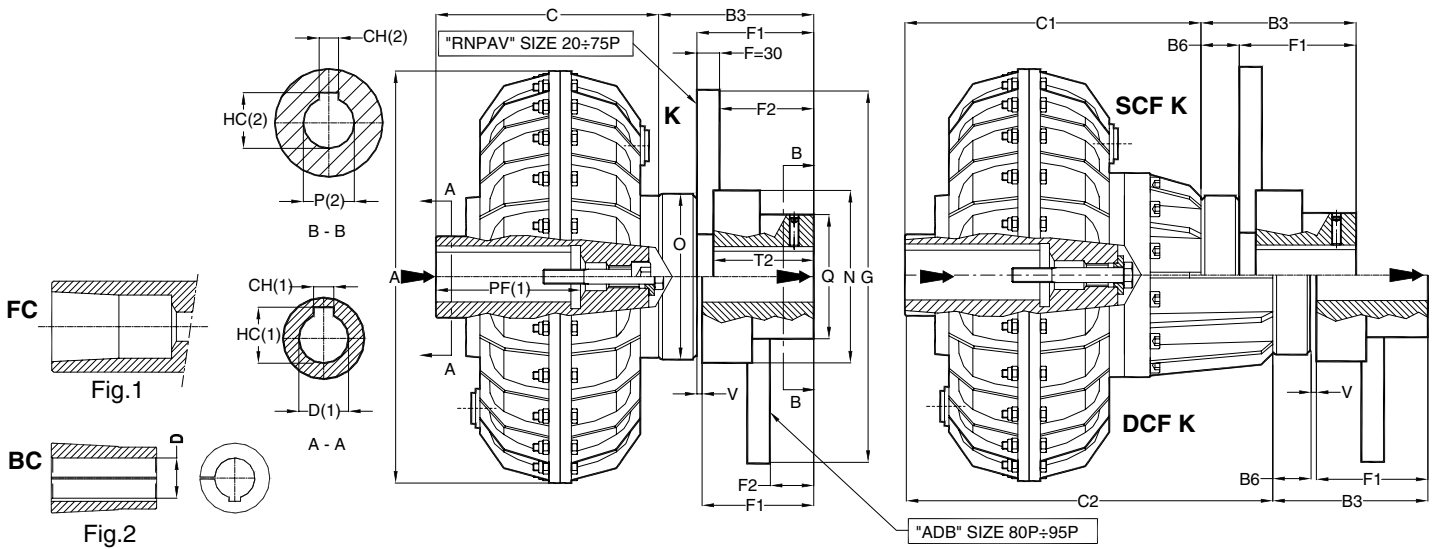

NOTES: (1) for bore and keyway dimensions see sheet 10-019E / (2) upon request: bore P finished / (3) the arrows ► indicate input and output

ROTOFLUID SIZE	Dimensions in mm										K			SCF K			DCF K			ELASTIC ELEMENT WITH BRAKE DISC
	Foro D	A	B3	B6	O	P Max	Q	N	V	Type	mm	kg*	Type	mm	kg*	Type	mm	kg*		
											C	Weight		C1	Weight		C2	Weight		
20	24-28	230	93	22	110	38	56	94	--	K1	125	6	--	--	--	--	--	--	RNPV2	
30	FC	290	111	30	140	48	68	118	--	K02	162	13,2	K02	217	15,6	K02	257	16,2	RNPV3	
30P	FC	327								K02			23,4			K02				24
40P	FC	338	120	34	176	60	91	147	--	K02	198	22	K02	256	25,7	K02	328	27,2	RNPV4	
50	FC	430	134	38	194	70	106	165	--	K02	179	30	K02	259	35,8	K02	334	38	RNPV5	
55	FC									K02	211	40	K02	291	45,8	K02	366	48		
60	FC 75	520	148	42	216	80	121	185	--	K02	192	46	K02	282	54,4	K02	362	58	RNPV6	
65	FC 75-80									K02	240	66	K02	330	74,4	K02	410	78		
70P	80-90 100	640	164	48	266	100	146	226	--	K2N	240	86	K2N	350	99	K2N	465	106	RNPV7	
75P	80-90 100	640	220	84	309	110	156	270	--	K2N	265	117	--	--	--	--	--	--	FRNPV8	
	80-90 100									K3N	280		K2M	347	135	K2M	462	147	RNPV8	
80P	Max.110 Max.125**	810	196	50	330	110	170	330	6	K2N	270	180	K2N	388	196	K2N	488	208	ADB8	
85P	Max.125 Max.130									K3N	286		K3N	404		K3N	504			
90P	Max.130 Max.140** Max.160***	1000	318	62	550	180	290	550	6	K2	364	350	K2	424	302	K2	504	317	ADB9	
										K3	464	390	K3	524	342	K3	604	357		
										K5	504	410	K5	564	362	K5	644	377		
95P	Max.130 Max.140** Max.160***	1000	318	62	550	180	290	550	6	K2	479	505	K2	599	545	K2	679	560	ADB9	
										K3	586	555	K3	706	595	K3	786	610		
										K5	626	575	K5	746	615	K5	826	630		

* Weight with oil and without Brake Disc RNPV o ADB - ** Bore depth PF=210 - *** Bore depth PF=250

DIMENSIONS ARE NOT BINDING

• Supplied with OVERSIZED CHAMBER SCFM or DCFM

□ Couplings with conical bore FC are supplied with Taper Bush BC and fixing screw (Fig. 1 and 2) - see page 14

BRAKE DISC RNPV / FRNPV with elastic coupling

ROTOFLUID	20	30/30P	40P	50/55				60/65				70P				75P																
Brake Disc	RNPV2	RNPV3	RNPV4	RNPV5				RNPV6				RNPV7				FRNPV8				RNPV8												
øG	200	200	250	315	250	315	355	400	315	355	400	450	500	560	630	400	450	500	560	630	450	500	560	630	710	800	450	500	560	630	710	800
F1	71	81	86	96				106				116				136				136												
F2	41	51	56	66				76				86				106				106												
T2	45	55	60	70				80				90				110				110												
Weight kg	7,3	8,6	13,7	21,1	16,1	22,6	27,6	33,9	25,2	30,1	36,3	43,6	52,4	64,2	79,6	40,5	48,4	57,2	69,0	84,6	68,6	76,4	88,2	103,5	121,5	146,5	45,6	54,4	66,2	81,9	101,5	126,7

BRAKE DISC ADB with elastic coupling

ROTOFLUID	80P										85P					90P/95P				
Brake Disc	ADB8										ADB8M					ADB9				
øG	450	500	560	630	710	800	900	1000	630	710	800	900	1000	710	800	900	1000	1250		
F1	140										170					250				
F2	50										80					143				
Weight kg	99	103	107	122	142	167	199	234	172	192	215	248	283	325	350	382	417	520		

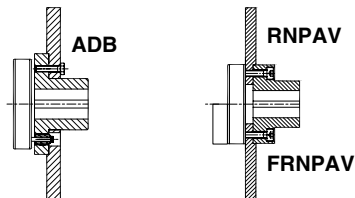

Example of order of a coupling with taper bush: ALFA 55 K02 FC + 55BC L15 D=60 + RNPV5 315x30 P=48

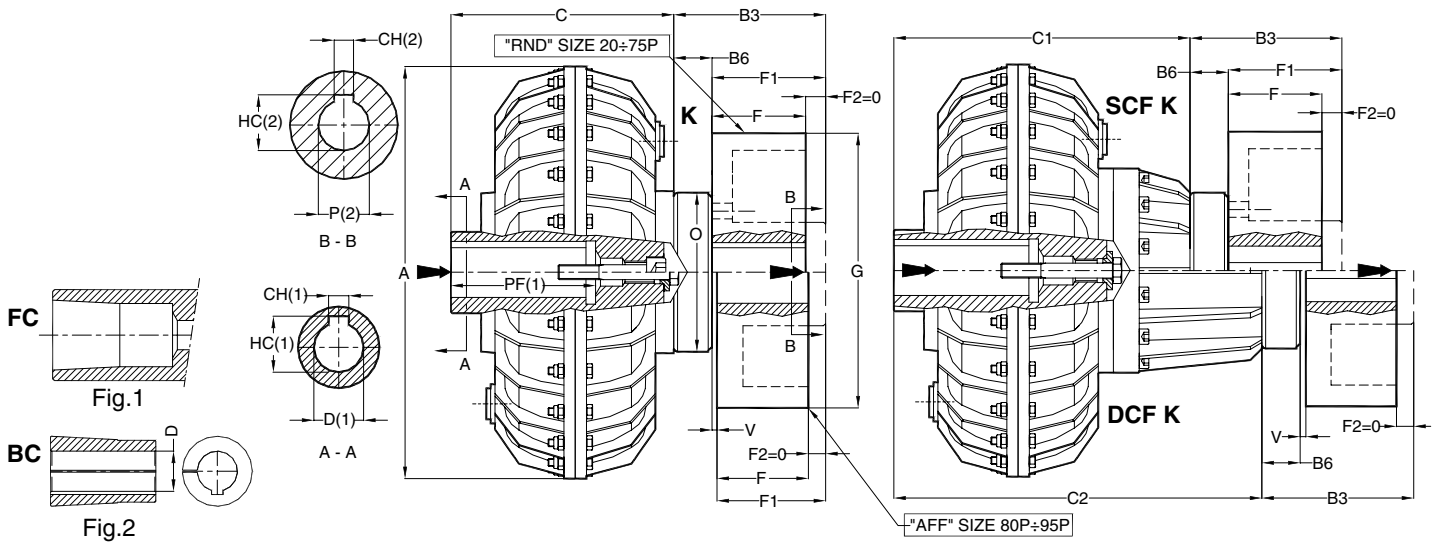

NOTES: (1) for bore and keyway dimensions see sheet 10-019E / (2) upon request: bore P finished / (3) the arrows ► indicate input and output

ROTOFLUID SIZE	Dimensions in mm				K			SCF K			DCF K			ELASTIC ELEMENT WITH BRAKE DRUM			
					Type	mm		kg*	Type	mm		kg*	Type		mm		kg*
	Bore D	A	O	V		B6	C	Weight		B6	C1	Weight			B6	C2	Weight
30	□FC	290	140	--	K02	30	162	13,2	K02	30	217	15,6	K02	30	257	16,2	RND3
30P	□FC	327			21			K02	23,4			24					
40P	□FC	338	176	--	K02	34	198	22	K02	34	256	25,7	K02	34	328	27,2	RND4
50	□FC	430	194	--	K02	38	179	30	K02	38	259	35,8	K02	38	334	38	RND5
55	□FC				211		40	K02	291		45,8	K02	366		48		
60	□FC 75	520	216	--	K02	42	192	46	K02	42	282	54,4	K02	42	362	58	RND6
65	□FC 75-80				240		66	K02	330		74,4	K02	410		78		
70P	80-90 100	640	266	--	K2N K3N	48	240 280	86	K2N K3N	48	350 390	99	K2N K3N	48	465 505	106	RND7
75P	80-90 100	640	309	--	K2N K3N	84	265 280	117	--	--	--	--	--	--	--	--	FRND8
	80-90 100				--	--	--	K2M K3M	56	375 390	135	K2M K3M	56	490 505	147	RND8	
	80P				Max.110 Max.125**	810	330	6	K2N	50	270	180	K2N	50	388	196	K2N
85P	Max.125 Max.130	400	6	K2N K3N	50		340	252	K2N K3N	50	458 458	280	K2N K3N	50	558 558	300	AFF8M
90P	Max.130 Max.140** Max.160***	1000	550	6	K2 K3 K5	62	364 464 504	350 390 410	K2 K3 K5	62	424 524 564	302 342 362	K2 K3 K5	62	504 604 664	317 357 377	AFF9
95P	Max.130 Max.140**				K2 K3 K5	479 586 626	505 555 575	K2 K3 K5	599 706 746	545 595 615	K2 K3 K5	62	679 786 826	560 610 630			
	Max.160***				K2 K3 K5	479 586 626	505 555 575	K2 K3 K5	599 706 746	545 595 615	K2 K3 K5	62	679 786 826	560 610 630			

* Weight with oil and without Brake Drum - ** Bore depth PF=210 - *** Bore depth PF=250

DIMENSIONS ARE NOT BINDING

• Supplied with OVERSIZED CHAMBER SCFM or DCFM

□ Couplings with conical bore FC are supplied with Taper Bush BC and fixing screw (Fig. 1 and 2) - see page 14

BRAKE DRUM RND with elastic coupling

ROTOFLUID	30/30P		40P			50/55				60/65				70P		75P-K		75P SCF K/DCF K						
Brake Drum	RND3		RND4			RND5				RND6				RND7		FRND8		RND8						
øG	160	200	250	160	200	250	315	200	250	315	400	200	250	315	400	500	315	400	500					
F=F1	60	75	95	60	75	95	118	75	95	118	150	75	95	118	150	190	118	150	190					
B3	90	105	125	94	109	129	152	113	133	156	188	117	137	160	192	166	198	238	202	234	274	174	206	246
P max	48	48	48	60	60	60	60	70	70	70	70	80	80	80	80	100	100	100	110	110	110	110	110	110
Weight kg	4,4	6,6	14	5	7,8	14,6	25,8	8,5	15,6	27,4	46,3	9,6	17,6	30,3	50	31,3	55,8	112	59	82,7	142	46,5	70,2	130

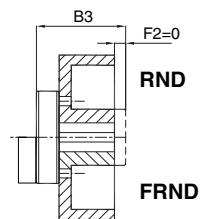

BRAKE DRUM AFF with elastic coupling

ROTOFLUID	80P			85P		90P/95P	
Brake Drum	AFF8			AFF8M		AFF9	
øG	400	500	630	500	630	630	710
F=F1	150	190	236	190	236	236	265
B3	206	246	292	246	292	304	333
P max	110	110	110	160	160	180	180
Weight kg	105	161	208	193	252	305	341

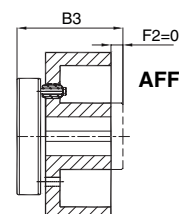

Example of order of a coupling with taper bush: ALFA 55 K02 FC + 55BC L15 D=60 + RND5 315x118 P=48

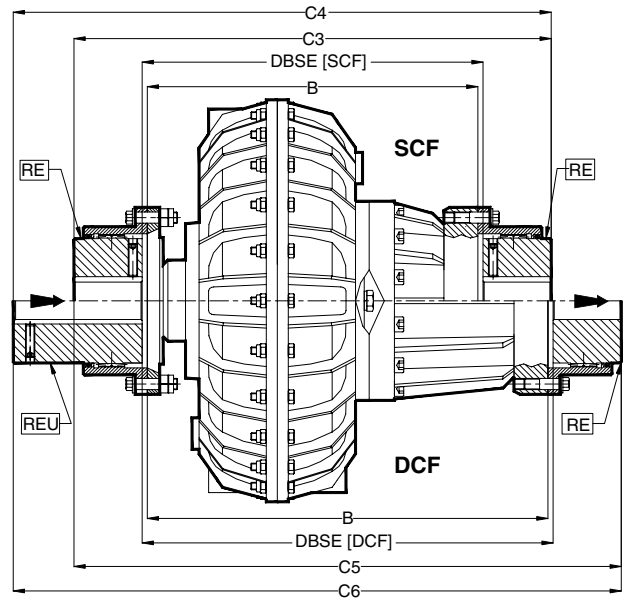
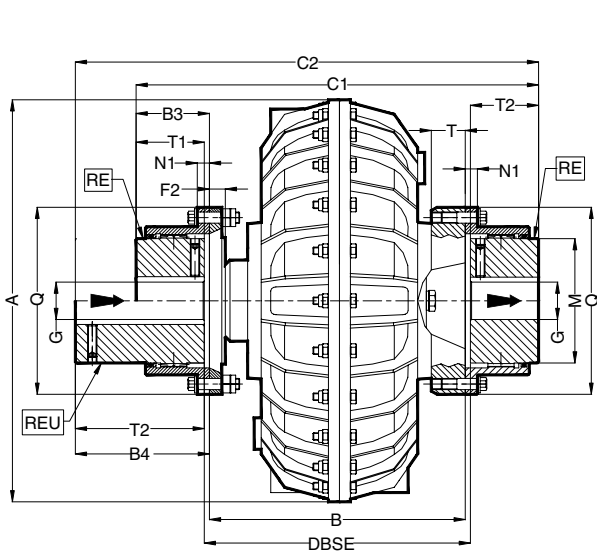

NOTES: (1) upon request: bore G finished / (2) the arrows ► indicate input and output / (3) reverse mounting is possible upon request

ROTOFLUID SIZE	Dimensions in mm								WAG-G					WAG-GU								
									GEAR COUPLING	Dimensions in mm				kg*	GEAR COUPLING	Dimensions in mm				kg*		
	A	B	F2	M	N1	Q	T	DBSE		C1	G		B3	T1		Weight	C2	G		B4	T2	Weight
20	230	162	14	69	12	111	23	165	RE40	251	10	45	44,5	43	13	RE40U	313	10	45	106,5	105	15
30	290	197	12	85	10	142	23	200	RE55	300	18	60	51,5	50	26,5	RE55U	365	18	60	116,5	115	29,5
30P	327																					
40P	338	233						236		336				36,2		401					39,5	
50	430	214						217		317				44,2		382					47,5	
55	430	256,5					28	261,5	RE85	413,5				79,3		487,5					85	
60	520	265	17,5	133	13	200	55,5	270		422	40	95	78,5	76	86	RE85U	496	40	95	152,2	150	92
65		313						318		470				107,2		544					113	
70P	640	293,5						298,5	RE100	478,5				146,7		558,5					156	
75P		348,5	23	152	13	225	60,5	353,5		533,5	50	110	92,5	90	187,5	RE100U	613,5	50	110	172,5	170	197
80P	810	370						376	RE120	586				262		666					274	
85P		440	28	178	22	265	72	446		656	60	130	108	105	324	RE120U	736	60	130	188	185	349
90P	1000	440						448	RE180	748				550		893					595	
95P		555	34	254	24	370	42	563		863	95	190	154	150	710	RE180U	1008	95	190	299	295	800
120P	1300	512	50	305	25	438	49	520	RE220	900	120	230	194	190	2200	RE220U	1015	120	230	309	305	2245
125P	UPON REQUEST								RE250	UPON REQUEST					RE250U	UPON REQUEST						

ROTOFLUID SIZE	Dimensions in mm		SCF						Dimensions in mm		DCF								
			WAG-G			WAG-GU					WAG-G			WAG-GU					
	B	DBSE	GEAR COUPLING	mm	kg*	GEAR COUPLING	mm	kg*	B	DBSE	GEAR COUPLING	mm	kg*	GEAR COUPLING	mm	kg*			
30	252	255	RE55	355	28,5	RE55U	420	31	292	295	RE55	395	29,5	RE55U	460	31,5			
30P																	36,5		
40P	291	294		394	40		459	39,5	363	366		466	41		531	44			
50	294	297		397	50		462	53	369	372		472	52		537	55			
55	336,5	341,5		493,5	85		567,5	91	411,5	416,5		568,5	87		642,5	93			
60	355	360	RE85	512	76	94,5	RE85U	586	100,5	435	440	RE85	592	76	98	RE85U	666	150	104
65	403	408		560	115,5		634	121,5	483	488		640	119		714	125			
70P	403,5	408,5	RE100	588,5	90	160	RE100U	668,5	169	518,5	523,5	RE100	703,5	90	166,5	RE100U	783,5	170	179
75P	458,5	463,5		643,5	200,5		723,5	209,5	573,5	578,5		758,5	207,5		838,5	216,5			
80P	488	494	RE120	704	105	278	RE120U	784	280,5	588	594	RE120	804	105	290	RE120U	884	185	302,5
85P	558	564		774	374		854	398	658	664		874	392		954	416			
90P	500	508	RE180	808	150	542	RE180U	953	587	580	588	RE180	888	150	557	RE180U	1033	295	602
95P	675	683		983	750		1128	840	755	763		1063	855		1208	945			

* Weight with oil

• Supplied with OVERSIZED CHAMBER SCFM or DCFM

DIMENSIONS ARE NOT BINDING

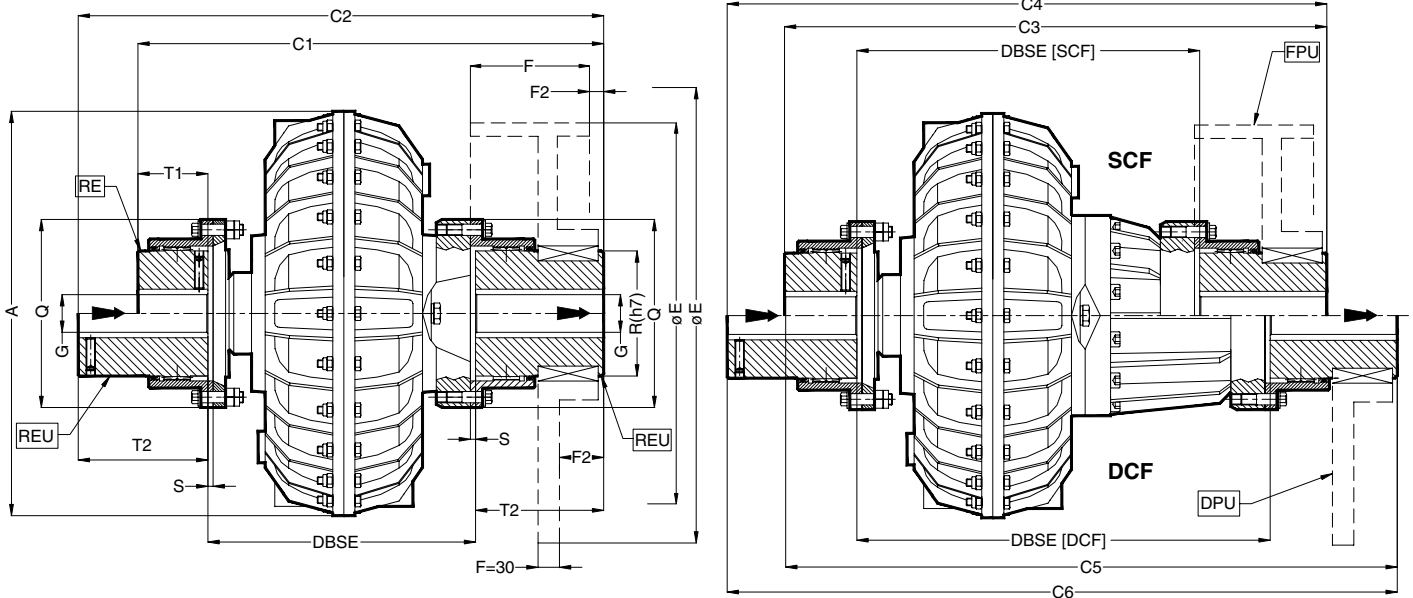

NOTES: (1) upon request: bore G finished / (2) the arrows ► indicate input and output

ROTOFLUID SIZE	GEAR COUPLINGS		Dimensions in mm								SCF					DCF									
	Standard Hub	Long Hub	A	G min	G max	Q	R (h7)	S	T1 RE	T2 RE U	WAG-GPU		WAG-GPUU		WAG-GPU		WAG-GPUU		WAG-GPU		WAG-GPUU				
											mm	kg*	mm	kg*	mm	kg*	mm	kg*	mm	kg*	mm	kg*	mm	kg*	
30	RE55	RE55U	290	18	60	142	80	1,5	50	115	DBSE	C1	W.	C2	W.	DBSE	C3	W.	C4	W.	DBSE	C5	W.	C6	W.
30P			200								365	28,9	430	31,3	255	420	485	33,3	295	460	31,9	525	34,3		
40P			236								401	38,6	466	41	294	459	42,4	524	44,8	366	531	43,4	596	45,8	
50			217								382	46,6	447	49	297	462	52	527	54,5	372	537	54,4	602	56,8	
55	RE85	RE85U	430	40	95	200	125	2,5	76	150	261,5	487,5	85,3	561,5	91	341,5	567,5	91	641,5	97	416,5	642,5	93	716,5	99
60			270								496	92	570	98	360	586	101	660	107	440	666	104	740	110	
65			318								544	113	618	119	408	634	122	708	128	488	714	125	788	131	
70P	RE100	RE100U	640	50	110	225	145	2,5	90	170	298,5	558,5	156	638,5	165	408,5	668,5	169	748,5	178	523,5	783,5	176	863,5	185
75P			353,5								613,5	196	693,5	206	463,5	723,5	210	803,5	219	578,5	838,5	217	918,5	226	
80P			376								666	275	746	287	494	784	291	864	303	594	884	303	964	315	
85P	RE120	RE120U	810	60	130	265	175	3	105	185	416	736	378	816	399	534	854	428	934	449	634	954	447	1034	469
90P			448								893	595	1038	640	508	953	587	1098	632	588	1033	602	1178	647	
95P	RE180	RE180U	1000	95	190	370	245	4	150	295	563	1008	755	1153	800	683	1128	795	1273	840	763	1208	810	1353	855
120P			520								900	2200	1015	2245	UPON REQUEST					UPON REQUEST					

* Weight with oil • Supplied with OVERSIZED CHAMBER SCFM or DCFM

Example of order with standard hub: ALFA 80P SCF WAG-G RE120PU G(m)= 100 G(r)=90

Example of order with long hub: ALFA 80P SCF WAG-G RE120PUU G(m)= 100 G(r)=90

BRAKE DRUM FPU

ROTOFLUID	30-30P-40P-50				55-60-65				70P-75P			80P-85P			90P-95P			120P		
Type FPU	FPU-55				FPU-85				FPU-100			FPU-120			FPU-180			FPU-220		
Ø E	160	200	250	315	400	250	315	400	315	400	500	400	500	630	500	630	710	630	710	800
F	60	75	95	118	150	95	118	150	118	150	190	150	190	236	190	236	265	236	265	300
F2	UPON REQUEST																			
Z	0	0	0	3	35	0	0	0	0	0	20	0	5	51	0	0	0	0	0	0
Weight kg	5,4	9,2	14,5	29	50,8	19,5	30,8	52,8	35,9	58,3	96,8	57	95,6	134	105	142	178	145	180	254

BRAKE DISC DPU

ROTOFLUID	30-30P-40P-50				55-60-65				70P-75P			80P-85P			90P-95P			120P							
Type DPU	DPU-55				DPU-85				DPU-100			DPU-120			DPU-180			DPU-220							
Ø E	250	315	355	400	355	400	450	500	500	560	630	710	500	560	630	710	800	1000	710	800	1000	1250	800	1000	1250
F2	41	41	41	41	45	45	45	45	60	60	60	60	60	60	60	60	60	60	105	105	105	105	UPON REQUEST		
Weight kg	11,7	18,5	23,5	28,8	25,2	31,5	38,5	47,3	51	63	78	98	50	61,6	77	97	122	188	105	130	197	300			

DIMENSIONS ARE NOT BINDING

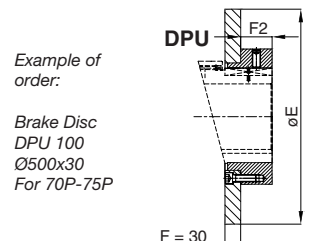
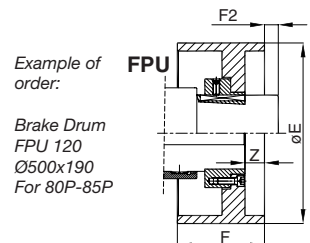

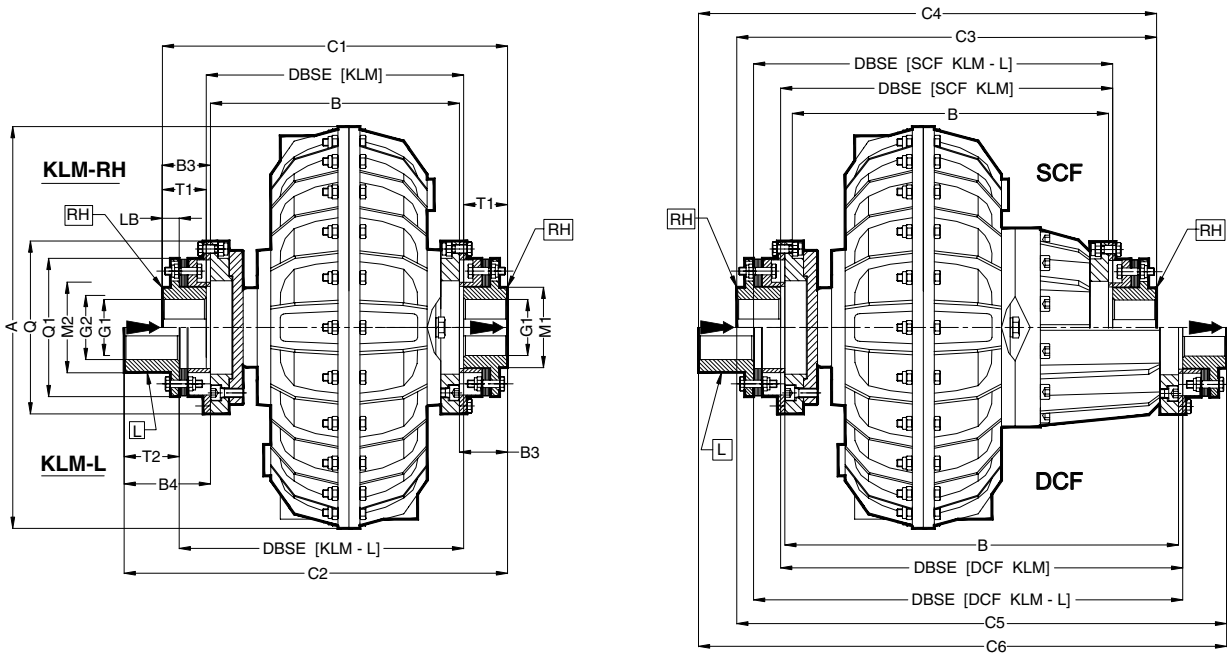

NOTES: (1) upon request: bore G finished / (2) the arrows ► indicate input and output / (3) reverse mounting is possible upon request

ROTOFLUID SIZE	DISC COUPLING HBSX	KLM-RH											KLM-L											
		Dimensions in mm											kg*		Dimensions in mm								kg*	
		A	B	C1	G1 max	DBSE	B3	LB	M1	Q	Q1	T1	Weight	C2	G2 max	DBSE	B4	M2	T2	Weight				
30	170	290	214	303	48	217	44,5	16,3	64	155	119	43	26,4	346,7	55	243,7	88,2	75	60	27,2				
30P		327	250	339		253							34,2			243,7				35				
40P		338	250	339		253							37			279,7				55	37,8			
50	330	430	234	337	65	237	51,5	18	86	185	148	50	51,6	389	65	269	103,5	92	70	52,9				
55		266	369	269		61,6							421			301				62,9				
60	650	520	256	383	85	259	63,5	25	120	260	214	62	94,5	468	95	296	148,5	135	110	101,5				
65		304	431	307		114,5							516			344				121,5				
70P	1260	640	276	433	100	281	78,5	28	138	295	246	76	161	525	110	329	170,5	155	120	169,4				
75P		331	488	336		192							580			384				200,4				
80P	2700	810	360	576	105	366	108	35	150	330	275	105	322	666	120	436	198	165	125	328,9				
85P	3160		606	125	123		41	175	365	308	120	357	710	135	445	227	190	145	366,7					
90P	3160	1000	430	676	125	436	123	41	175	365	308	120	429	780	135	515	227	190	145	438,7				
95P	4630		461	707	125	467	123	41	175	365	308	120	530	811	135	546	227	190	145	545,3				
120P	4630	576	854	140	584	139	46	195	415	346	135	740	973	150	673	258	215	165	755,3					
UPON REQUEST																								

* Weight with oil

DIMENSIONS ARE NOT BINDING

ROTOFLUID SIZE	DISC COUPLING HBSX	SCF KLM-RH				SCF KLM-L				ROTOFLUID SIZE	DISC COUPLING HBSX	DCF KLM-RH				DCF KLM-L					
		mm				kg*						mm				kg*					
		B	DBSE	C3	T1	Weight	DBSE	C4	T2			Weight	B	DBSE	C5	T1	Weight	DBSE	C6	T2	Weight
30	170	269	272	358	43	28,8	298,7	401,7	60	29,6	170	309	312	398	43	29,4	338,7	441,7	60	30,2	
30P		36,6	37,4	38,2																	
40P		41,4	42,2	43																	
50	330	314	317	417	50	57,4	349	469	70	58,7	330	389	392	492	50	59,6	424	544	70	60,9	
55		67,4	381	501		68,7	421	424		524		69,6	456	576		70,9					
60	650	346	349	473	62	102,9	386	558	110	109,9	650	426	429	553	62	106,5	466	638	110	113,8	
65		122,9	434	606		129,9	474	477		601		126,5	514	686		133,5					
70P	1260	386	391	543	76	174	439	635	120	182,4	1260	501	506	658	76	181	554	750	120	189,4	
75P		205	494	690		213,4	556	561		713		212	609	805		220,4					
80P	2700	810	478	484	694	105	338	554	784	125	344,9	3160	578	584	794	105	350	654	884	125	356,9
85P	3160		724	120	373	563	828	145	382,7	80P	3160		648	654	894	120	477	733	998	145	486,7
90P	3160	1000	521	527	767	120	482	606	871	145	497,3	4630	601	607	847	135	497	686	951	145	512,3
95P	4630		696	704	974	135	780	793	1093	165	795,3		4630	776	784	1054	135	795	873	1173	165

• Supplied with OVERSIZED CHAMBER SCFM or DCFM

Example of order : ALFA 55KLM-L 330 RH (with 1 RH hub and 1 L hub)

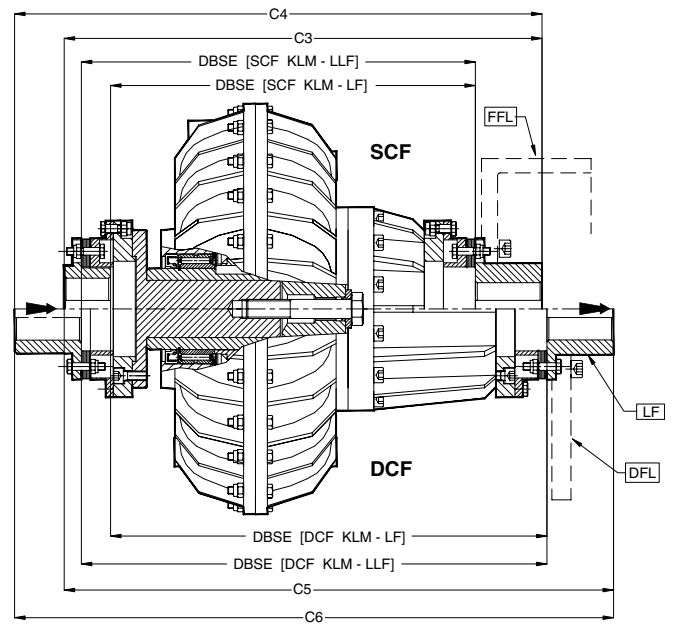
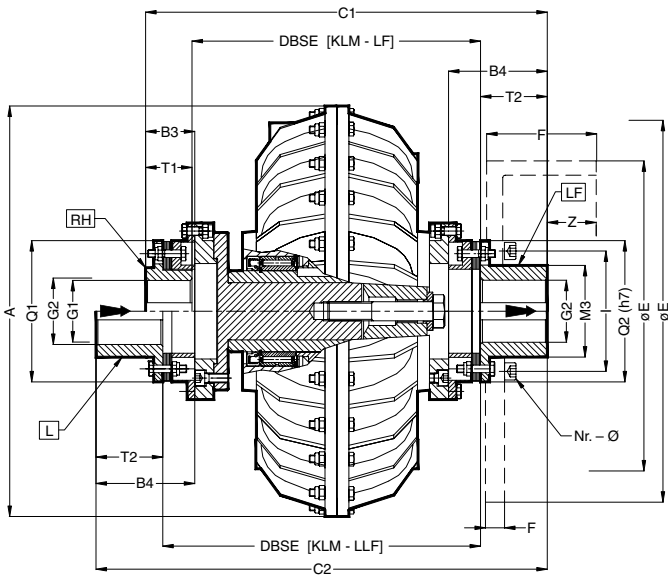

NOTES: (1) upon request: bore G finished / (2) the arrows ➡ indicate input and output

ROTOFLUID SIZE	DISC COUPLING HBSX	mm																											
		KLM								SCF KLM				DCF KLM															
		LF		LLF		LF		LLF		LF		LLF		LF		LLF													
A	B3	B4	ØG1 max	ØG2 max	M3	Q1	Q2	DBSE	C1	T1	W.	DBSE	C2	T2	W.	DBSE	C3	W.	DBSE	C4	W.	DBSE	C5	W.	DBSE	C6	W.		
30	170	290							243,7	346,7	43	27,2	270,4	390,4	60	28	298,7	401,7	29,6	325,4	445,4	30,4	338,7	441,7	30,2	365,4	485,4	31	
30P		327	44,5	88,2	48	55	75	119	118,5			35				35,8			37,4			38,2			38,2	365,4	485,4	39	
40P		338								279,7	382,7	43	37,8	306,4	426,4	60	38,6	337,7	440,7	42,2	364,4	484,4	43	409,7	512,7	43	436,4	556,4	43,8
50	330	430							269	389		52,9	301	441		54,2	349	469	58,7	381	521	60	424	544	60,9	456	596	62,2	
55		430	51,5	103,5	65	65	92	148	147,5			62,9	333	473		64,2	381	501	68,7	413	553	70	456	576	70,9	488	628	72,2	
60		520								296	468		101,5	333	553		108,5	386	558	109,9	423	643	116,9	466	638	113,8	503	723	123
65	650	520	63,5	148,5	85	95	135	214	213			121,5	381	601		128,5	434	606	129,9	471	691	136,9	514	686	133,5	551	771	140,5	
70P		640							329	525		169,4	377	617		177,8	439	635	182,4	487	727	190,8	554	750	189,4	602	842	197,8	
75P		640	78,5	170,5	100	110	155	246	245	384	580	76	200,4	432	672	120	208,8	494	690	213,4	542	782	221,8	609	805	220,4	657	897	228,8
80P	2700 3160	810	108	198	105	120	165	275	274	436	666	105	328,9	506	756	125	335,8	554	784	344,9	624	874	351,8	654	884	356,9	724	974	363,8
85P		123	227	125	135	190	308	307	445	710	120	366,7	524	814	145	377,4	563	828	382,7	642	932	392,4	663	928	394,7	742	1032	404,4	
90P	3160	1000	123	227	125	135	190	308	307	515	780	120	438,7	594	884	145	448,4	633	898	466,7	712	1002	476,4	733	998	486,7	812	1102	496,4
95P		1000	139	258	140	150	215	346	346	673	973	135	755,3	762	1092	165	770,6	793	1093	795,3	882	1212	810,6	873	1173	810,3	962	1292	825,6
120P	UPON REQUEST																												

* Weight with oil

DIMENSIONS ARE NOT BINDING

BRAKE DRUM FFL

ROTOFLUID	30-30P-40P				50-55				60-65				70P-75P				80P		85P-90P		95P	
FFL	FFL 170				FFL 330				FFL 650				FFL 1260				FFL 2700		FFL 3160		FFL 4630	
Ø E	160	200	250	315	200	250	315	400	250	315	400	315	400	500	400	500	500	630	630	630	710	
F	60	75	95	118	75	95	118	150	95	118	150	118	150	190	150	190	190	236	236	236	265	
F2	0	-	-	-	-	-	-	-	15	-	-	2	-	-	-	-	-	-	-	-	-	
Z	0	15	35	58	5	25	48	80	-	8	40	-	30	70	25	65	45	91	71	100		
I	100				128				195				224				216		282		314	
Nr.-Ø	8 M10				8 M12				16 M12				16 M14				8 M20		16 M20		16 M20	
Weight kg	4	6,8	11,5	28	6,5	11,1	27,7	49,1	9,9	25	47,5	24	46	85	46,1	84,7	83,3	121	119	154,8		

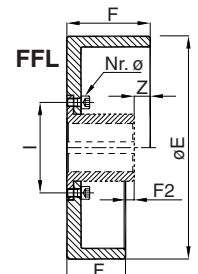

BRAKE DISC DFL

ROTOFLUID	30-30P-40P				50-55				60-65				70P-75P				80P		85P-90P		95P					
DFL	DFL 170				DFL 330				DFL 650				DFL 1260				DFL 2700		DFL 3160		DFL 4630					
Ø E	250	315	355	315	355	400	450	400	450	500	500	560	630	710	800	500	630	710	800	630	710	800	710	800	1000	1250
F	30			30				30				30				30			30							30
F2	27,5			34,5				70				79				81			96							113
I	100				128				195				224				216		282		314					
Nr.-Ø	8 M10				8 M12				16 M12				16 M14				8 M20		16 M20		16 M20					
Weight kg	10,5	17	22,3	16	21,8	28	35,9	26,2	34	42,8	41,7	53,5	70	88,8	114	41,2	53	68,4	88,2	66,7	86,5	112	84,7	109,8	176,3	280,3

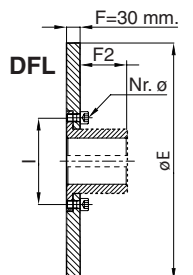

* Supplied with OVERSIZED CHAMBER SCFM or DCFM

Example of order: ALFA 55 SCF KLM 330 LF G(m)=60 G(r)=40 with Brake Drum FFL 330 ØE 315x118

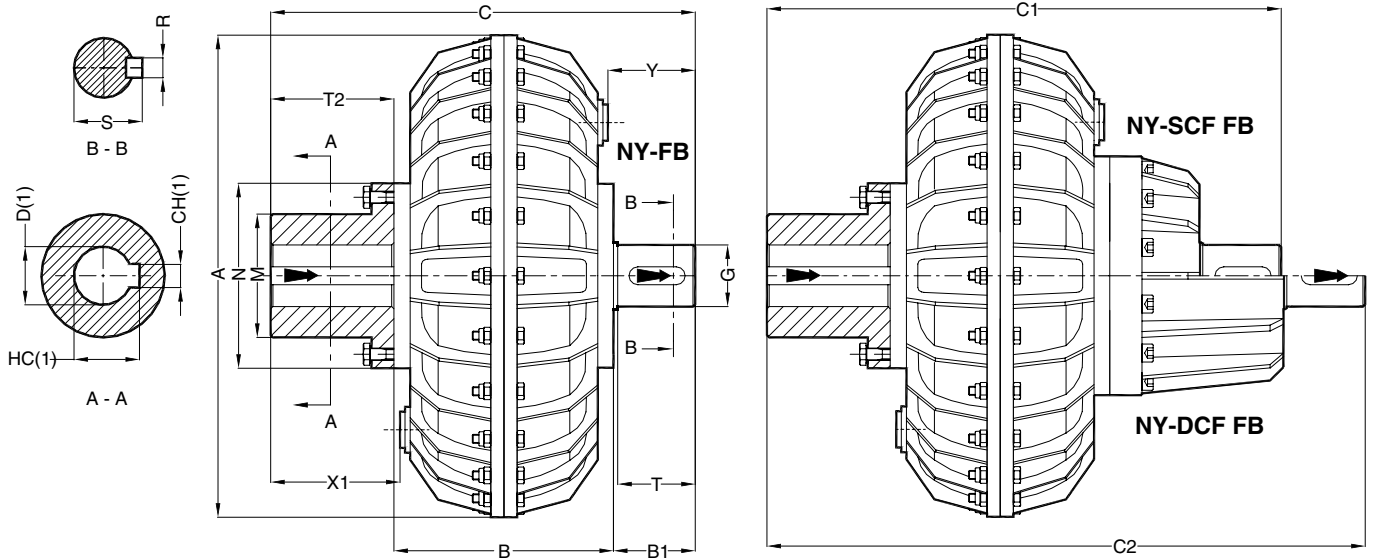

NOTES: (1) for bore and keyway dimensions see sheet 10-019E / (2) the arrows ► indicate input and output

ROTOFLUID SIZE	NY-FB														NY-SCF FB		NY-DCF FB		
	Dimensions in mm														kg*	mm	kg*	mm	kg*
	D ^{G7}	A	B	B1	C	G ^{H7}	N	M	R	S	T	T2	X1	Y	Weight	C1	Weight	C2	Weight
30	28	290	150	51	261	38	116	80	10	41	45	60	69	55	19	316	21,5	356	22,1
	38																		
30P	28	327	150	51	261	38	116	80	10	41	45	60	64	55	28	316	30,5	356	31,1
	38																		
40P	38	338	183	61	324	48	145	91	14	51,5	55	80	104	72	31	382	35	454	37
50	42-48-55	430	154	71	325	55	165	110	16	59	65	100	106	91	44	405	50	480	52
	60-65-75				367														
55	42-48-55	520	172	86	368	60	185	135	18	64	80	110	116	77	54	447	60	522	62
60	48-55																		
65	55	220	172	86	368	60	185	135	18	64	80	110	116	92	91	506	99	586	103
	60-65-75																		
70P	65-75	640	190	96	426	70	225	160	20	74,5	90	140	140	111	129	536	142	651	149
	80-90				481														
75P	65-75	245	190	96	426	70	225	160	20	74,5	90	140	140	96	170	591	183	706	190
	80-90				481														
80P	60-65-75	810	226	116	482	80	270	170	22	85	110	140	140	131	238	600	254	700	266
	80-90				556														
85P	60-65-75	300	226	116	482	80	270	170	22	85	110	140	140	116	310	674	336	774	348
	80-90				556														
90P	80-90-95	1000	344	186	700	110	345	250	28	116	180	170	170	240	470	760	510	840	530
	100-110				700														
90P	100-110	1000	344	186	700	110	345	250	28	116	180	170	170	240	470	760	510	840	530
	120-140				700														

* Weight with oil

DIMENSIONS ARE NOT BINDING

● Supplied with OVERSIZED CHAMBER SCFM or DCFM

Example of order: ALFA 55 NY-FB D=65
ALFA 55 NY-SCF FB D=65
ALFA 55 NY-DCF FB D=65

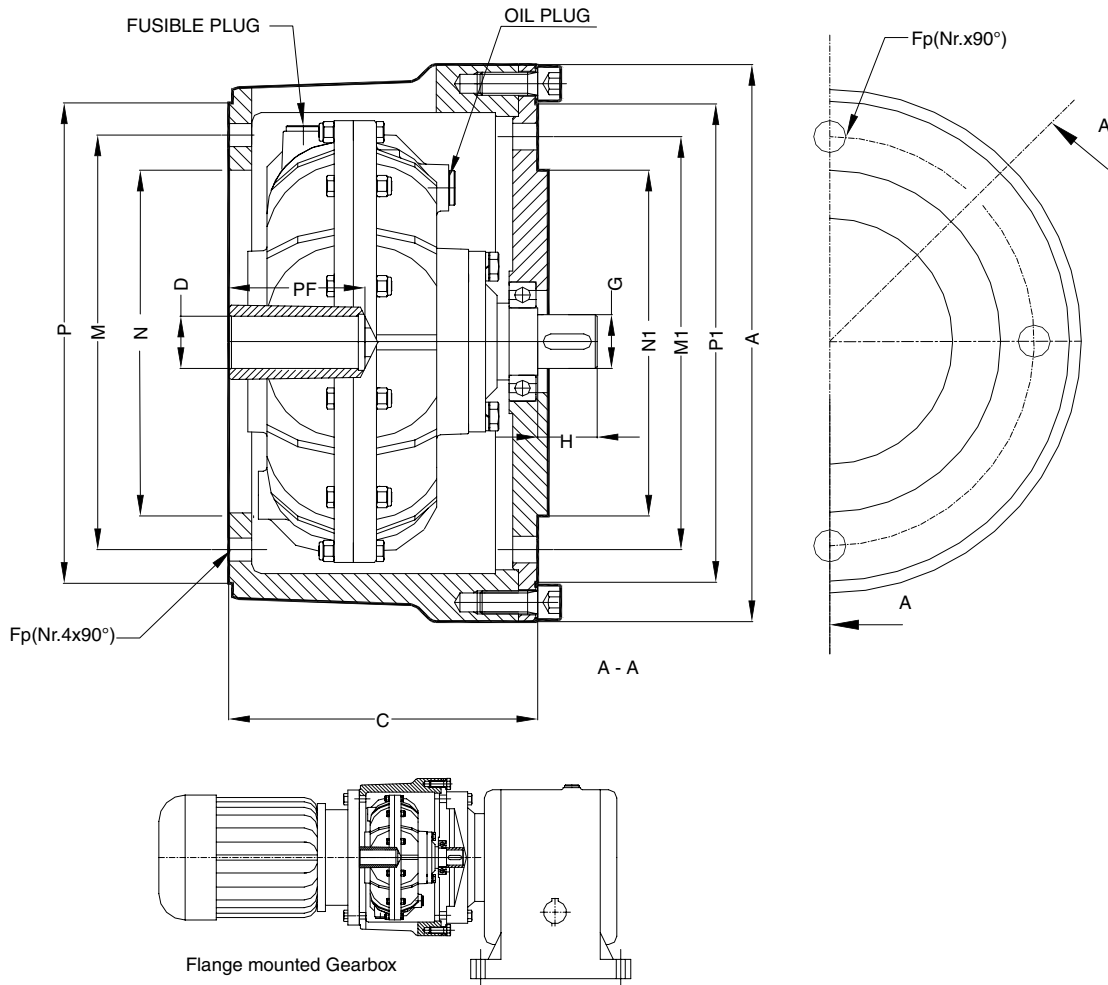

COUPLING		MOTOR		Dimensions in mm												kg*	
Grand.	Tipo	Tipo	kW	A	C	D	Fp	G h7	H	M	M1	N F7	N1 h7	P	P1	PF	Weight
10	CKS-19-19	80	0,55	240	128	19 G7	ø11	19	25	165	165	130	130	200	200	40	8,5
			0,75			24 G7		24								50	
	CKS-24-24	90 S	1,1			24											
90 L		1,5	24														
20	CKS-28-28	100	2,2	292	161	28 G7	ø13	28	32	215	215	180	180	250	250	60	24
			3					38									
30	CKS-38-38	132S 132M	5,5	350	210	38 F7	ø13	38	45	265	265	230	230	300	300	80	36,5
			7,5					42									
30P	CKS-42-42	160 M 160 L	11	400	210	42 F7	ø17	42	55	300	300	250	250	350	350	110	40
			15					48									
40P	CKS-48.48	180 M 180 L	18,5	400	255	48 F7	ø17	48	55	300	300	250	250	350	350	110	42
			22					48									

* Weight with oil

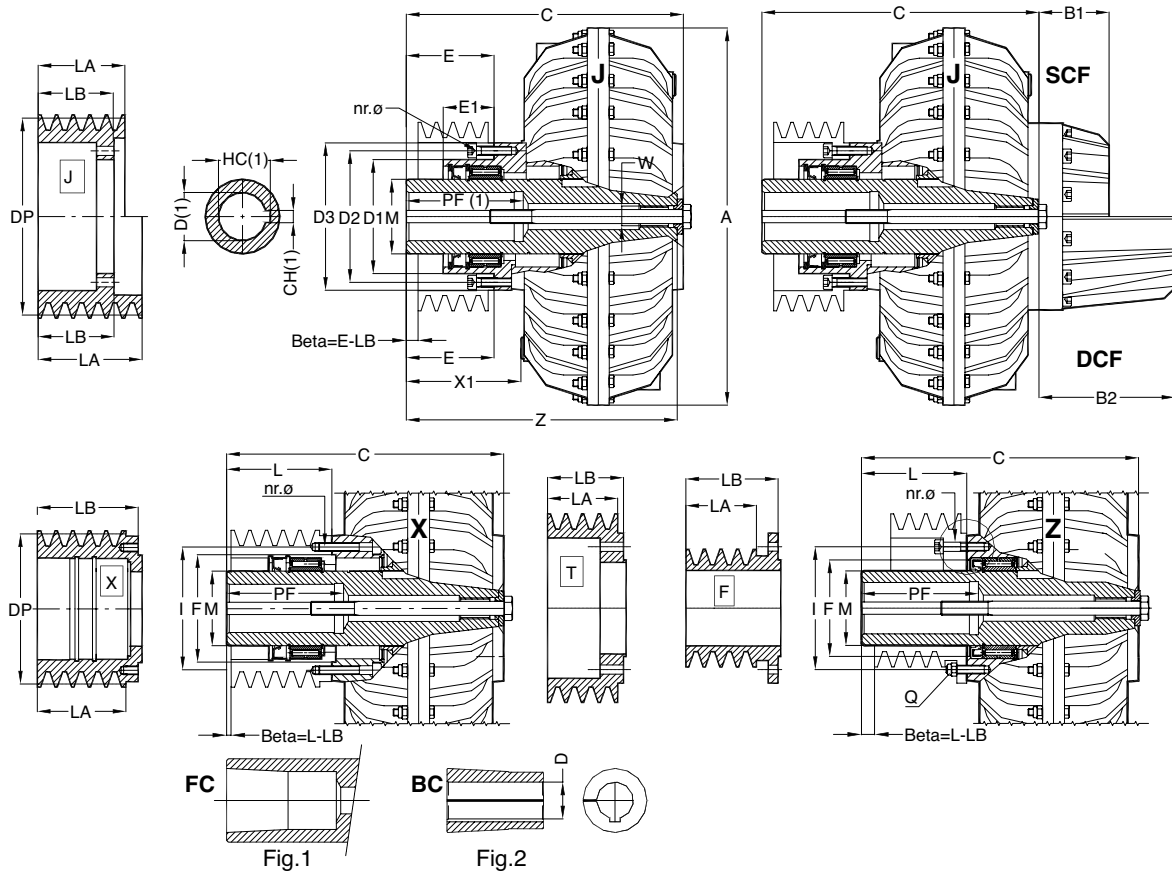

NOTES: (1) for bore and keyway dimensions see sheet 10-019E / (2) for the choice of the assembly coupling-pulley, LA - LB quotes, see WESTCAR Pulley
(3) X couplings are supplied with X type pulleys for pitch diameters less than the minimum diameters of the J type pulleys

ROTOFLUID SIZE	Type	Dimensions in mm																	J		X / Z		SCF		DCF	
		Bore D	A	C	D1 ^{H7}	D2	D3	E	E1	F ^{H7}	I	L	M	Nr.-Ø	X1	Z	W	Weight kg*	Weight kg*	B1	Weight kg*	B2	Weight kg*			
10	Z 55	24	192	143	-	-	-	-	47	60	55	35	6-M6	57	140	M10	-	4,2	-	-	-	-				
20	Z 70	28	229	185	-	-	-	-	62	78	70	45	6-M8	76	180	M14	-	6,5	-	-	-	-				
30	J / X / Z 88	□FC	290	238	85	100	114	70	45	75	100	88	60	8-M8	97	233,5	M24	16,3	14,8	55	2,4	95	3			
30P	J / X / Z 88	□FC	327															24,3	22,8							
40P	J / X / Z 90	□FC	338	273	112	130	145	89	60	100	125	90	70	8-M8	114	268	M24	28	25	58	4	130	5			
	J / X / Z 118	□FC		301				117										118	142					296	29	26
50	J / X 90	□FC	430	244	130	150	170	70	58	110	140	90	85	8-M10	95	241,5	M24	33	31	80	6	155	8			
	J / X 120	□FC		274				100										120	125					271,5	35,5	32,5
55	J / X 155	□FC		351				135				155			160	348,5		46	43							
60	J / X 130	75-80 - □FC	520	302	150	170	184	110	88	125	160	130	110	8-M10	135	302	M30	60	55	90	8,4	170	12			
	J / X 170			342				150										170	175					342	62	57
65	J / X 130	75-80 - □FC	520	350	150	170	184	110	88	125	160	130	110	8-M10	135	350	M30	74	69	90	8,4	170	12			
	J / X 170			390				150										170	175					390	77	72
70P	J / X 170	80-90-100	640	380	188	210	230	140	100	150	195	170	120**	8-M12	169	369	M36	120,5	111	110	13	225	20			
	J / X 210			420				170										209	409					123,5	114	18
75P	J / X 210	80-90-100		470				180				210			209	459		156,5	147		18		30			
80P	J / X 255A	80-90-100-110	810	481	214	240	270	225	130	190	230	255	140	8-M14	254	475	M36	222,5	207	118	16	218	28			
85P	J / X 255A	80-90-100-110		555				225										225	549					303,5	290	28

* Weight with oil

DIMENSIONS ARE NOT BINDING

• Supplied with OVERSIZED CHAMBER SCFM or DCFM

□ Couplings with conical bore FC are supplied with Taper Bush BC and fixing screw (Fig. 1 and 2)
In case of mounting on shafts without shoulder contact WESTCAR

Example of order of a coupling for taper bush: BETA 55 J155 FC

Example of order of a coupling with taper bush: BETA 55 J155 FC + 55BC L155 D=60

TAPER BUSH BC WITH FIXING SCREW							
COUPLING SIZE	Type	Standard D Bore					Max D Bore
30/30P	3BC	38	42	48	-	-	48
40P	4BC	38	42	48	50	-	50
50 - 55	5BC	-	42	48	55	65	65
60 - 65	6BC	-	-	48	55	60	70

■ Taper Bushes are supplied without keyway

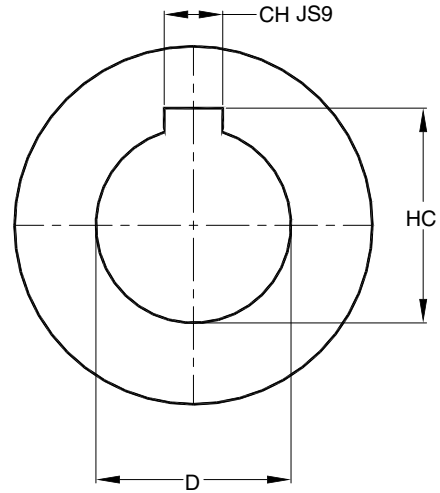
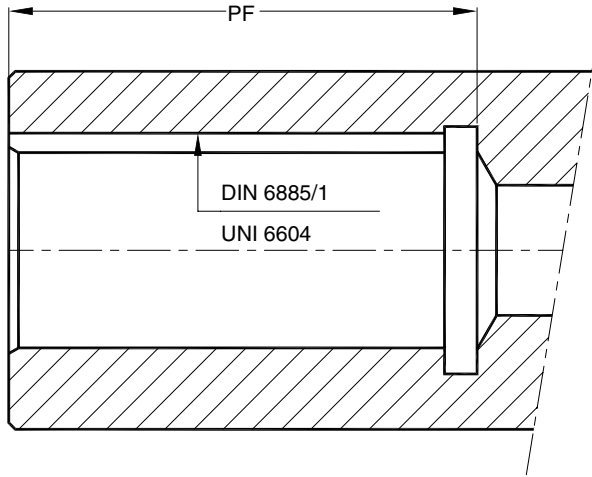

D	Tolerance	PF	CH	HC	Tolerance
10	H7	25	3	11,4	+0,1 0
11 *		25	4	12,8	
12		25	4	13,8	
13		30	5	15,3	
14 *			5	16,3	
15			5	17,3	
16			5	18,3	
17			5	19,3	
18			6	20,8	
19 *		40	6	21,8	
20			6	22,8	
21			6	23,8	
22		50	6	24,8	
23			8	26,3	
24 *			8	27,3	
25			8	28,3	
26			8	29,3	
27			8	30,3	
28 *	60	8	31,3		
30		8	33,3		
32		10	35,3		
33		10	36,3		
34	G7	80	10	37,3	
35			10	38,3	
38 *			10	41,3	
			10	41,3	

D	Tolerance	PF	CH	HC	Tolerance	
40	G7	110	12	43,3	+0,2 0	
42 *			12	45,3		
45			14	48,8		
48 *			14	51,8		
50			14	53,8		
55 *			16	59,3		
60 *			140	18		64,4
65 *				18		69,4
70 *				20		74,9
75 *				20		79,9
80 *	170	22	85,4			
85 *		22	90,4			
90 *		25	95,4			
95		25	100,4			
100 *	210	28	106,4			
105		28	111,4			
110 *		28	116,4			
115		32	122,4			
120	250	32	127,4			
125 *		32	132,4			
130		32	137,4			
135 *		36	143,4			
140		36	148,4			
160		40	169,4			
180		45	190,4			

* STANDARD BORES FOR UNEL MEC ELECTRIC MOTORS

FUSIBLE PLUG TF

In case of overheating, the fusible plug allows the oil out and thereby disconnects the power transmitted to the output shaft. Fusible plugs are available for four different melting temperatures: 96°C, 120°C, 140°C and 180°C.

WESTCAR standard couplings are supplied with fusible plug at 140° C.

THERMAL SWITCHING PIN TE

In case of coupling overheating with a thermal switching pin, a pin is released and collide against a limit switch which activates an alarm or shuts off the electric motor. This method avoids the oil leakage from the coupling.

Fusible switching pins are available for four different temperatures: 96°C, 120°C, 140°C and 180°C.

In case of stall conditions, motor running and machine locked, the coupling housing must be driving to guarantee the signal survey.

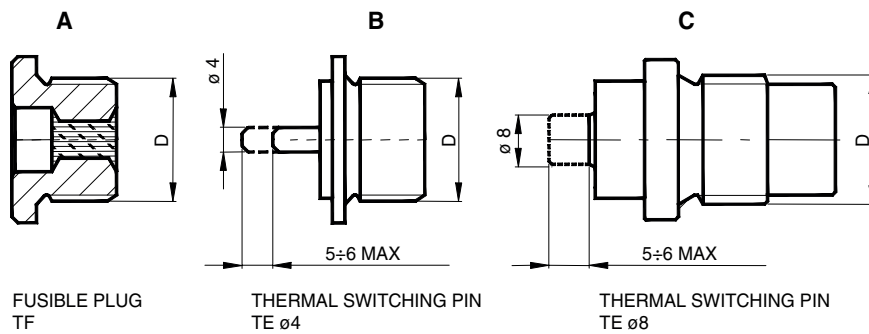

ROTOFLUID SIZE	DIMENSIONS				TEMPERATURE					
	D	A	B	C	96 °C BLUE	120 °C WHITE	140 °C RED	160 °C ORANGE	180 °C GREEN	199 °C LIGHT GREEN
10 20 30-30P 40P	1/4 GAS	X	X	-	•	•	•	•	•	•
50-55 60-65	1/2 GAS	X	X	-	•	•	•	•	•	•
70P-75P 80P-85P	1/2 GAS	X	-	X	•	•	•	•	•	•
90P-95P	3/4 GAS	X	-	X	•	•	•	•	•	•

When ordering specify: dimension D, safety plug melting temperature and colour.

Example of order: **Thermal switching pin TE ¼ GAS 140°C RED.**

THERMAL SWITCHING PIN STANDARD POSITION

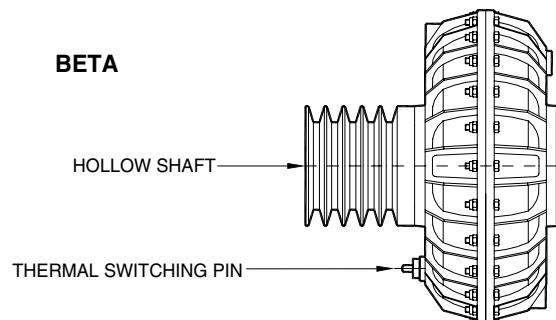
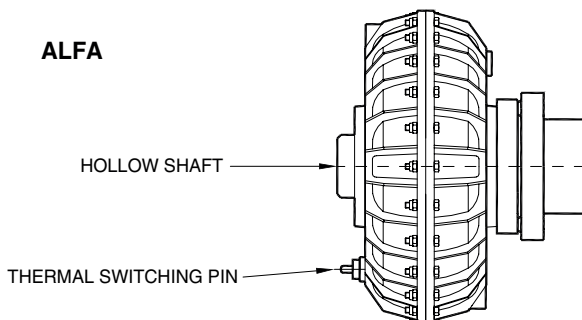

The thermal switching pin is normally mounted by the hollow shaft side but in case of need can be located in the opposite side.

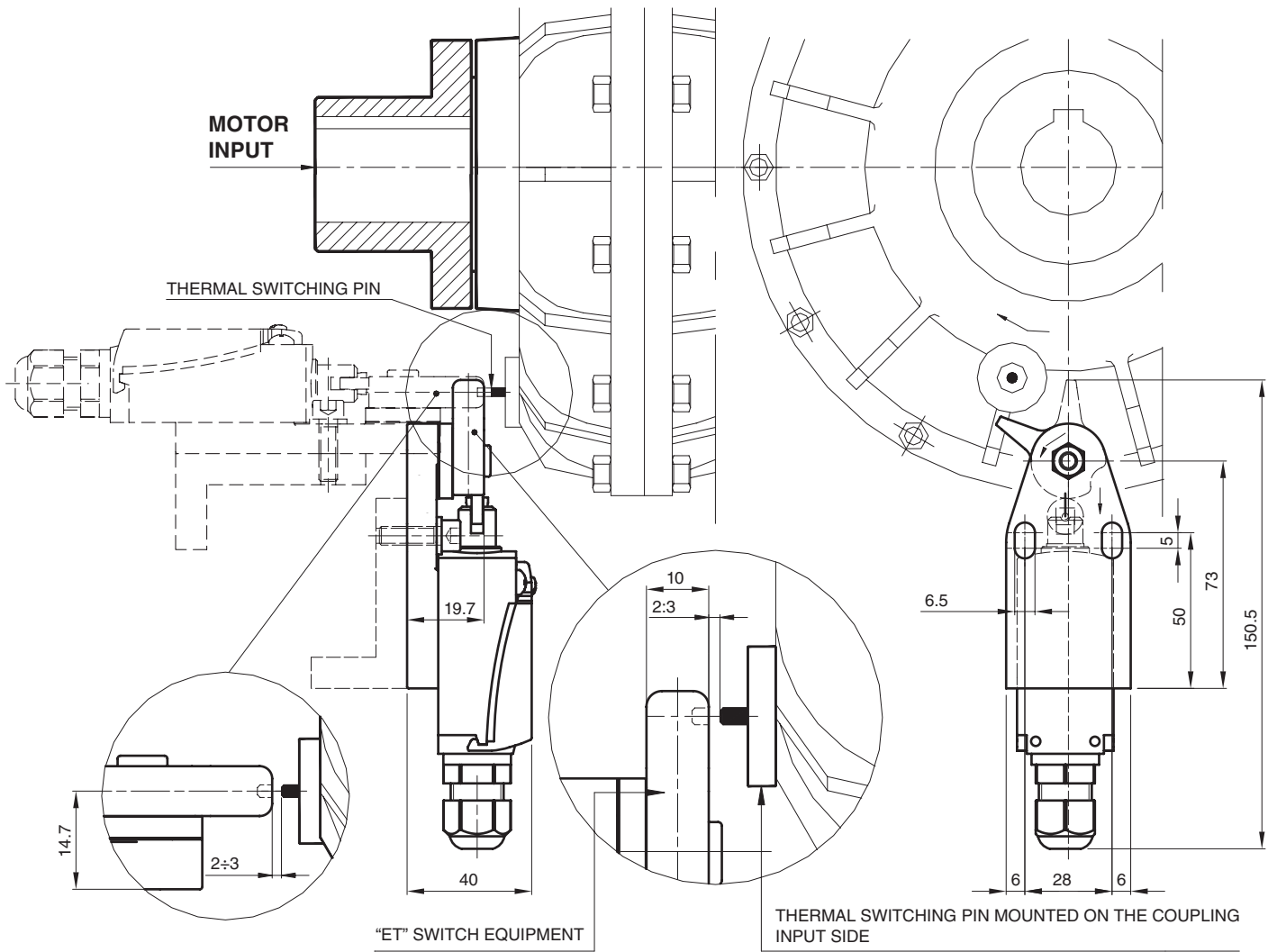

"ET" CONNECTED TO A LIGHT SOUND SIGNAL

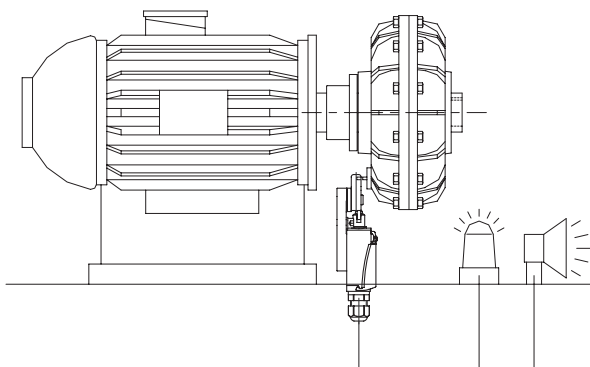

"ET" CONNECTED TO SWITCH OFF THE DRIVE

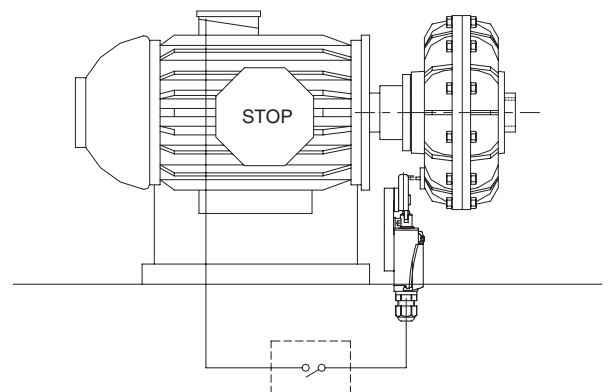

The ET safety device consists of a microswitch and a cam mounted on a base and operates in combination with a thermal switching pin fitted on the fluid coupling housing. In case of coupling overheating due to overloads and machine jams or reduced oil filling, the oil temperature can exceed the melting temperature set for the thermal switching pin. The pin then extends and makes contact with the cam of the microswitch sounding an alarm or shutting down the drive.

- A Rotofluid Coupling
- B LOGIC
- C PLUG "PM" no contact
- D Sensor SE

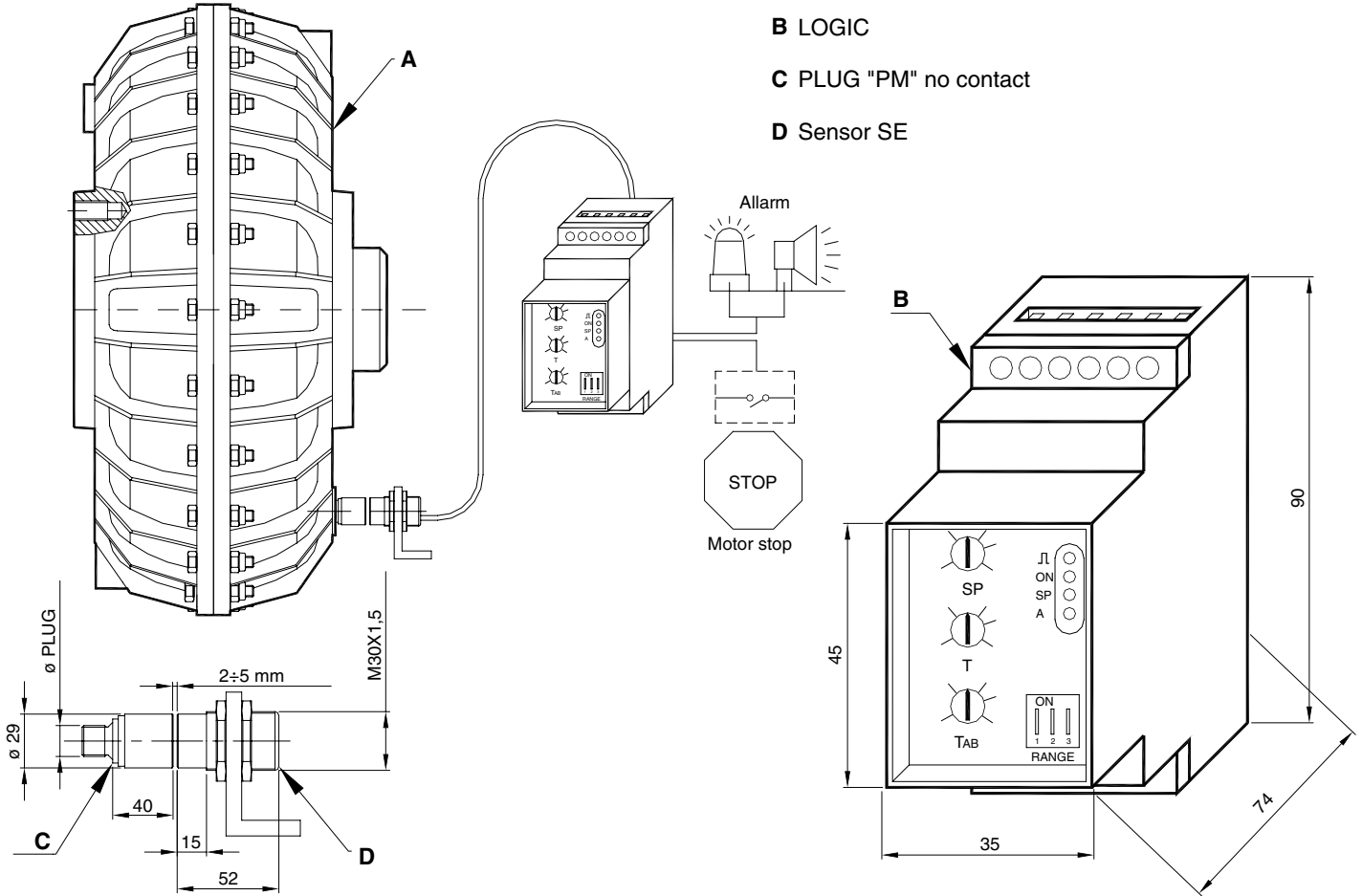

DEVICE T09 WITH PM

The Plug PM is fitted on the outer impeller, in contact with the oil inside the coupling.
The outer wheel of the coupling (A) can be connected to the machine (driven side) or connected to the motor (drive side).
If the Plug PM is mounted on the driven side the system detects the variation of temperature and speed. If it is mounted on the drive side the system detects only the temperature.

WORKING PRINCIPLE

The Plug PM contains a thermal element that changes its status at the temperature of 120°C (or upon request: 80°C, 100°C, 140°C or 160°C).

The plug PM, normally closed, crossing the SE sensor acts as a pulse generator, consequently the SE sensor sends impulses to the device LOGIC T09.

Once the temperature limit is reached the thermal element opens and the plug PM and the sensor SE no longer generate impulses. The device LOGIC T09 not receiving more signals, will switch the inner relay, providing an alarm signal or stopping the motor.

POWER SUPPLY: Standard tension 24Vac (upon request: 115 Vac, 230 Vac or 24Vdc).

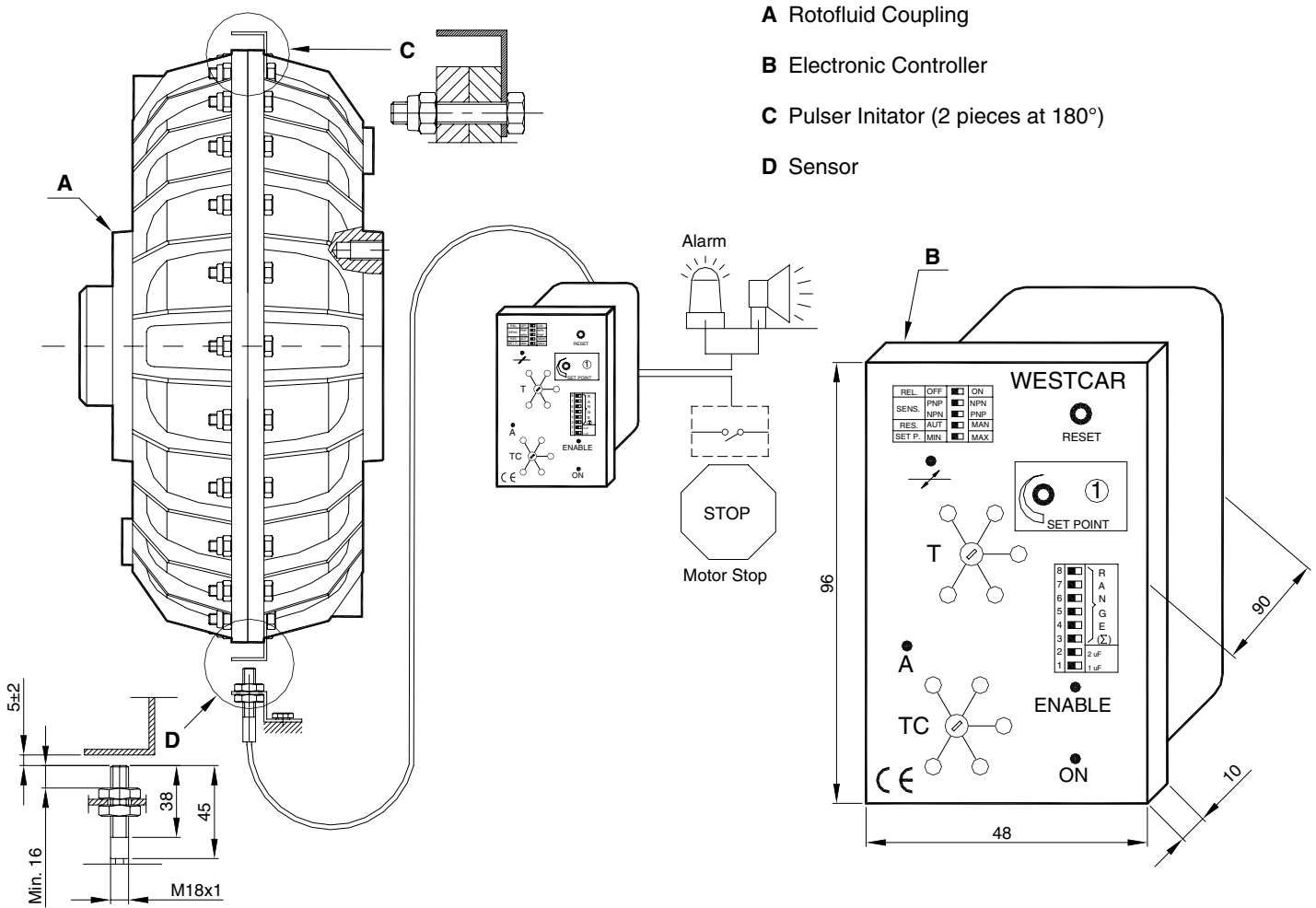

- A Rotofluid Coupling
- B Electronic Controller
- C Pulser Initiator (2 pieces at 180°)
- D Sensor

DEVICE SCD

The **SCD** Device can be applied to guarantee the safety of coupling the machine and the product quality. The **SCD** device is an electronic controller which receives a train of pulses by a sensor. The pulses are converted into a proportional voltage to the pulses frequency. This voltage is compared with a variable reference voltage (**SET POINT**). The internal relay changes over when the input speed is faster or lower than the fixed (**SET POINT**). It is used to control the shaft revolution speed. In case of speed decrease, the device gives a signal to the operator.

WORKING PRINCIPLE

As the transmitted torque is increased, this gives rise to an increased slip of the fluid coupling. Possible overload can be detected by measuring the resulting speed reduction in the driven half coupling by means of overload **SCD**. This with change-over contact at the output may either emit an alarm signal or switch off the main motor. A delaying action (max 120 sec) prevents the unnecessary triggering of the relay, when the motor is started. It only occurs once when the operating voltage is applied. False alarms are prevented arising from very short torque fluctuations, by the introduction of a preset time lag (max 30 seconds).

POWER SUPPLY: Standard tension 24 Vac (upon request: 115 Vac, 230 Vac or 24 Vdc).

SCREW PULLER "VE" TYPE

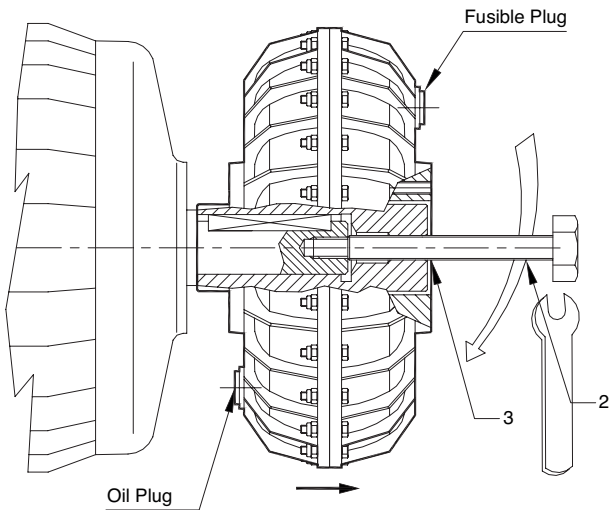

VE SYSTEM	ROTOFLUID COUPLING					
	SIZE	VERSIONS				
Type		K	Z	J	H	X
VE M14	20	K1	Z70	J70	H55	XN70
VE M16		K3	Z69	-	-	-
VE M20				J103	H85	X103
VE M24	30	ALL VERSIONS				
	30P					
	40P					
	50					
VE M30	55	UP TO Ø 65				
	55	FOR Ø75 Ø 80				
VE M36	60	ALL VERSIONS				
	65					
	70P					
	75P					
	80P					
	85P					
	90P					
95P						

To pull off the ROTOFLUID coupling proceed as follows:

- 1) Remove tightening screw
- 2) Tighten the screw (2) into the threaded hole of the coupling shaft (3), taking care to lock the rotation of the drive shaft.

PULLING OFF SYSTEM "SE" TYPE

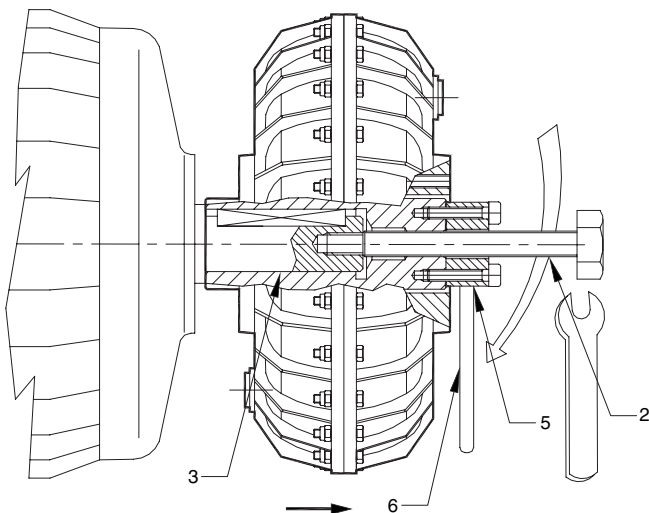

SE SYSTEM	ROTOFLUID COUPLING					
	SIZE	VERSIONS				
Type		K	Z	J	H	X
SE M20	20	-	-	J 103	H 85	X 103
SE M24/35	30	ALL VERSIONS				
SE M24/40	30P					
	40P					
	50					
SE M30	55	UP TO A Ø 65				
	55	FOR Ø75 Ø 80				
SE M36	60	ALL VERSIONS				
	65					
	70P					
	75P					
	80P					
	85P					
	90P					
95P						

To pull off the ROTOFLUID coupling proceed as follows:

- 1) Remove tightening screw
- 2) Lock the bush (5) to the shaft end (3) with 2 securing screws. Tight the screw puller (2) in the shaft threaded hole keeping locked the rod (6) to avoid the motor shaft rotation.

The mass moment of inertia values listed in the table below are referred to inner part, outer part and oil where:

- **INNER PART** = hollow shaft, impeller pump, half oil
- **OUTER PART** = turbine and cover housing, half oil

Values valid for ROTOFLUID couplings with oil level at 45° off center pulleys, flexible couplings and other accessories are not included. For couplings with delay fill chamber SCF/DCF, add their values to the correspondent of the outer part of the couplings.

INNER PART	OUTER PART	INNER PART	OUTER PART	DELAY CHAMBER
SIZES: 10, 20, 30, 30P, 40P, 50, 60, 70P, 80P, 90P		SIZES: 55, 65, 75P, 85P, 95P		

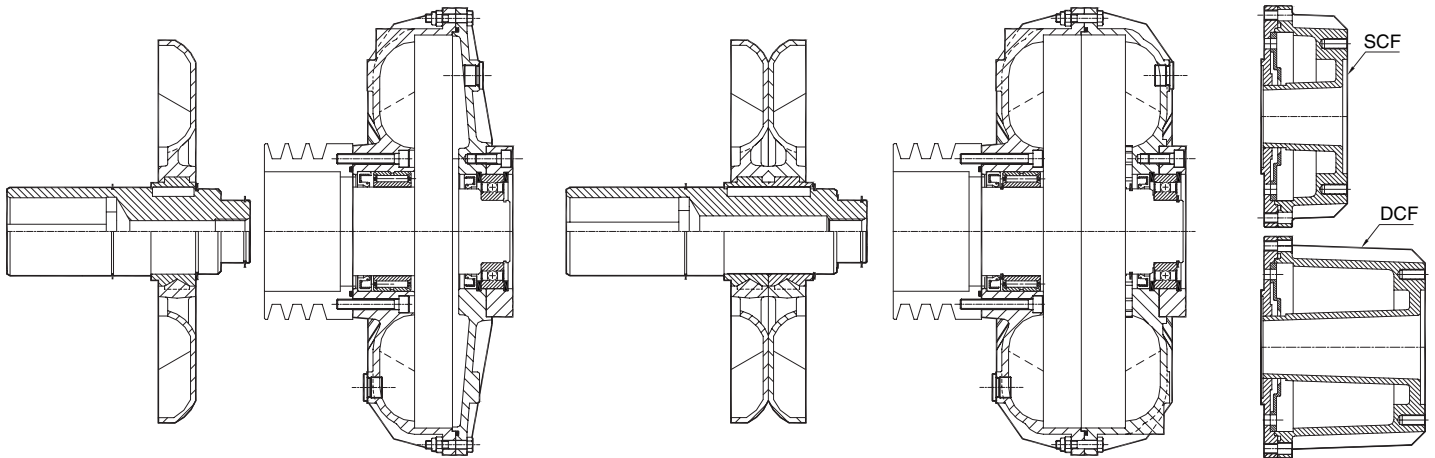

$$\text{MOMENT OF INERTIA } J = \frac{m \times R^2}{2} \text{ (Kgm}^2\text{)}$$

ROTOFLUID COUPLING SIZE	ALFA VERSION		BETA VERSION				DELAY CHAMBER			
	Type K		Type Z, X		Type J		Type H		SCF	DCF
	J INNER kgm ²	J OUTER kgm ²	J INNER kgm ²	J OUTER kgm ²	J INNER kgm ²	J OUTER kgm ²	J INNER kgm ²	J OUTER kgm ²	J kgm ²	J kgm ²
10	0,003	0,011	0,003	0,011	--	--	0,003	0,012	--	--
20	0,006	0,024	0,006	0,024	0,006	0,026	0,006	0,027	--	--
30	0,021	0,081	0,022	0,081	0,022	0,084	0,022	0,086	0,006	0,007
30P	0,040	0,140	0,045	0,140	0,045	0,144	0,045	0,147	0,006	0,007
40P	0,060	0,179	0,065	0,179	0,065	0,190	0,065	0,197	0,013	0,016
50	0,105	0,363	0,109	0,363	0,109	0,376	0,109	0,385	0,026	0,032
55	0,208	0,474	0,214	0,474	0,214	0,487	0,214	0,496	0,026	0,032
60	0,311	0,795	0,326	0,795	0,326	0,823	0,326	0,842	0,053	0,062
65	0,564	1,040	0,583	1,040	0,583	1,068	0,583	1,087	0,053	0,062
70P	0,678	2,386	0,740	2,386	0,740	2,473	0,740	2,551	0,160	0,200
75P	1,236	2,782	1,260	2,782	1,260	2,869	1,260	2,947	• 0,350	• 0,550
80P	2,389	7,276	2,499	7,276	2,499	7,393	--	--	0,350	0,550
85P	4,668	9,977	4,792	9,977	4,792	10,094	--	--	• 0,900	• 1,400
90P	8,372	23,200	--	--	--	--	--	--	1,200	1,600
95P	15,613	28,855	--	--	--	--	--	--	1,200	1,600
120P	54,000	260,000	--	--	--	--	--	--	--	--
125P	104,000	320,000	--	--	--	--	--	--	--	--

• OVERSIZED CHAMBER SCFM / DCFM

GENERAL DESCRIPTIONS THAT CHANGE THE BASE UNIT

ROTOFLUID COUPLING

OPTIONAL

SIZE	VERSION	BORE
		D.

[| | | | |]

IN LINE INSTALLATION

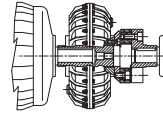

Standard

INSTALLATION WITH MOTOR SHAFT UP

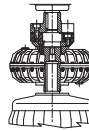

C1

INSTALLATION WITH MOTOR SHAFT DOWN

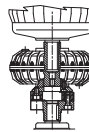

C2

FUSIBLE PLUG IN LINE

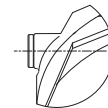

Standard

OIL PLUG PERPENDICULAR TO THE COUPLING AXIS

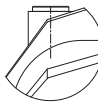

R

RETAINER FOR SEAL

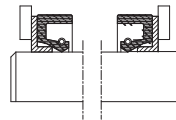

ZZ

OIL FILLING FOR AMBIENT TEMPERATURE -20°C TO +180°C (STANDARD)
OIL FILLING WITH FIRE RESISTANT OIL (I)
OIL FILLING FOR AMBIENT TEMPERATURE -40°C TO +160°C (B)

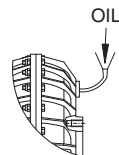

Standard

I

B

BEARINGS LUBRICATION WITH INNER COUPLING OIL

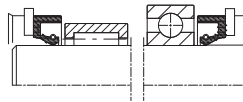

Standard

FORCED LUBRICATION FOR LONG LIFE LUBRICATED BEARINGS

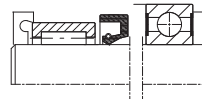

G

COUPLING FOR "VE" DISMOUNTING SYSTEM

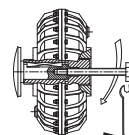

Standard

COUPLING FOR "S.E." DISMOUNTING SYSTEM

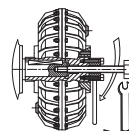

E

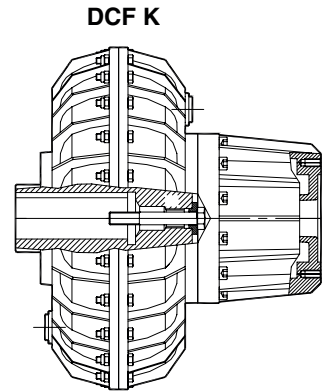
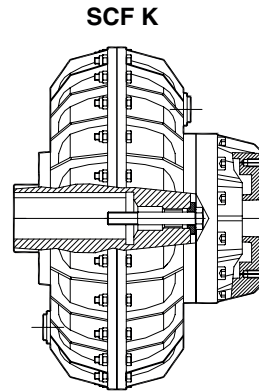
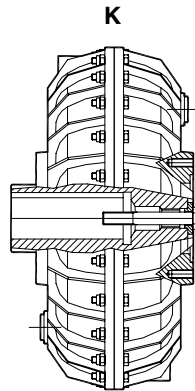
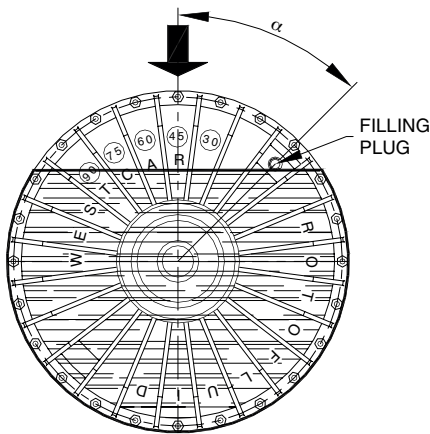

OIL REPLACEMENT

The oil in the coupling must be changed for the first time after 2000 working hours and subsequently after each 4000 working hours. To change the oil, proceed as follows:

- 1) Rotate the coupling to bring the filling plug to its highest position
- 2) Unscrew and remove the filling plug
- 3) Determine the correct filling level by rotating the coupling until the filling hole corresponds to the current oil level
- 4) Completely drain the oil in the coupling by bringing the filling hole to its lowest point
- 5) Rotate the coupling again to bring the filling hole to correspond to the filling level determined at point 3
- 6) Pour in the new oil until the oil filling level is reached.

The quantity and type of oil recommended is listed in Table 1.

Results achieved by decreasing the oil quantity:

- Slower and more gradual startings
- Less absorption of startings current
- Better protection to the transmission elements in the event of overload
- Higher slip value at running.

IMPORTANT:

An excessive decrease in the oil quantity can cause the following problems:

- The impossibility of rapidly accelerating the machine due to insufficient torque.
- The overheating of the coupling, with consequent damage to the oil seals.

Results achieved by increasing the oil quantity:

- Faster startings
- Lower slip value at running
- Higher absorption of starting current during acceleration phases
- Greater strain on transmission elements.

IMPORTANT:

An excessive oil quantity can cause the following problems:

- The overloading of the electric motor
- The cracking of the coupling housing due to the internal overpressure caused by the lack of internal space for sufficient oil expansion

TYPES OF OIL RECOMMENDED FOR STANDARD WORKING TEMPERATURE

Working Temperature from -20°C to +180°C

- TOTAL AZOLLA ZS 22 consigliato da WESTCAR
- BP ENERGOL HPL 22
- CASTROL HYPIN AWS 22
- Q8 VERDI 22
- SHELL TELLUS 22

Tab. 1

COUPLING SIZE	OIL QUANTITY FOR STANDARD FILLING					
	K		SCF K		DCF K	
	α	Liter	α	Liter	α	Liter
10	45°	0,55	--	--	--	--
20	45°	1,20	--	--	--	--
30	45°	2,39	55°	2,43	65°	2,42
30P	45°	4,05	55°	3,94	65°	3,78
40P	45°	4,07	55°	4,06	70°	4,09
50	45°	4,39	65°	4,37	75°	4,59
55	45°	7,19	60°	7,04	70°	7,17
60	45°	8,61	65°	8,23	75°	8,41
65	45°	13,48	60°	12,80	70°	12,77
70P	45°	18,05	65°	16,89	75°	17,64
•75P	45°	30,14	65°	29,36	75°	29,68
80P	45°	35,53	65°	35,21	75°	35,27
•85P	45°	60,64	65°	57,79	75°	56,28
90P	45°	91,92	60°	81,70	70°	90,62
95P	45°	153,3	60°	154,9	70°	146,7
120P	45°	185	--	--	--	--
125P	45°	360	--	--	--	--

• OVERSIZED CHAMBERS SCFM, DCFM

The coupling can be supplied with first fill oil on request

For more information, consult WESTCAR.

Do not exceed Quantity of oil indicated in Table 1.

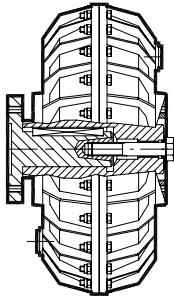

Fig. 1

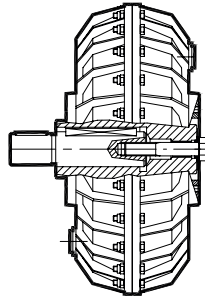

Fig. 2

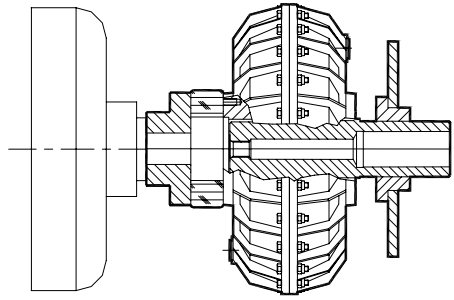

Fig. 3

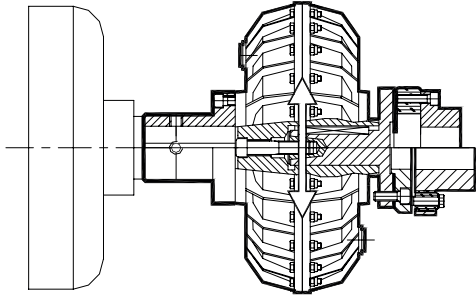

Fig. 4

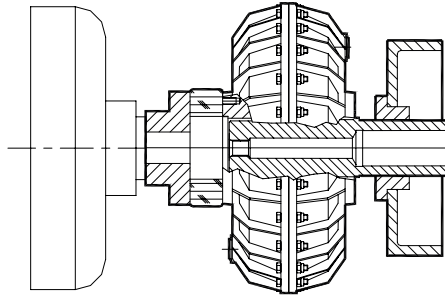

Fig. 5

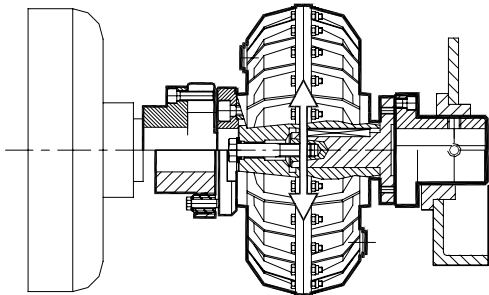

Fig. 6

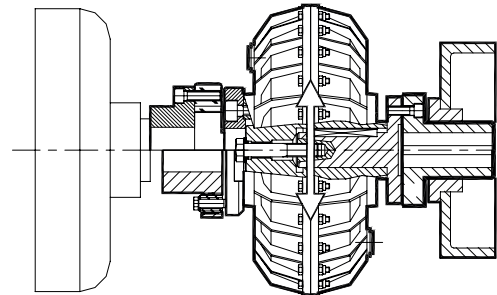

Fig. 7

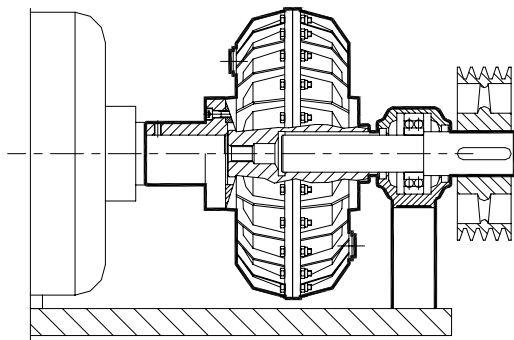

Fig. 8

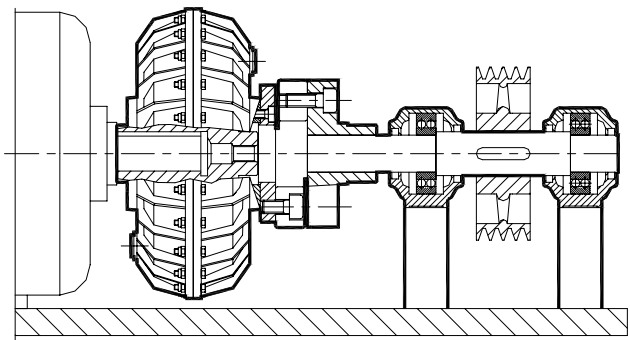

Fig. 9

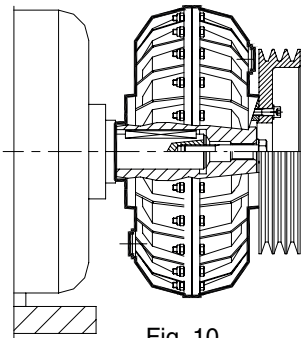

Fig. 10

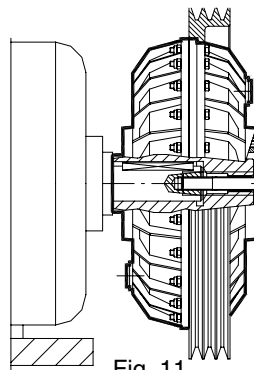

Fig. 11

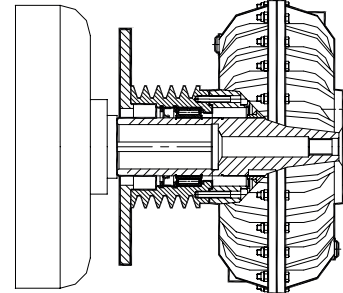

Fig. 12

BUILDING - CONSTRUCTION - MINING - BRICKS

- Tower Cranes
- Belt Conveyors
- Rotary kilns
- Crushers
- Rolling Mills
- Bucket elevators
- Rotating screens
- Rotary arrow
- Brick Moulders
- Kiln cars

TEXTILE

- Drum Tumblers
- Centrifuges
- Carding machines
- Industrial Washing machines
- Dryers

CHEMICAL - FOOD - CANNING

- Stirrers
- Dryers
- Decanters
- Rotating filters
- Soap cutters
- Calanders and gum mixers
- Palletizers
- Labelling Machine
- Bottling Plants
- Centrifugal separators

MECHANICAL ENGINEERING

- Twisting machines for rope and wire
- Rod iron straighteners
- Presses
- Profiling machines
- Drawbenches
- Cutters

AUTOMOTIVE INDUSTRY

- Balancing machines
- Gates open/closing drive

PAPER PROCESSING

- Winders
- Pulpers
- Mixers

TIMBER PROCESSING

- Drum barkers
- Hardboard presses
- Shredders

MARBLE PROCESSING

- Gantry cranes
- Multi-blade frames

ECOLOGY

- Blenders
- Sludge purification plant

CERAMICS

- Continuous and intermittent ball mills
- Mixers
- Presses

OTHERS

- Winches
- Windlasses
- Centrifugal and alternative compressors
- Suction and centrifugal fans
- Centrifugal pumps
- Fire pumps
- Elevators
- Cable cars
- Amusements park rides
- Haulage wagons in steelworks and mines
- Stack-up coating plants
- Sprayers
- Refineries
- Ski lift
- Sand mixers
- Fan & Blowers
- Refiners



ROTOFLUID



ROTOFLEXI



ROTOFLUID CA



ROTOGEAR RE



ROTOMECH



ROTOGEAR AR



DRUM BRAKES BD



STEELFLEX



DRUM BRAKES CD



ROTOPIN

Discover more

Products



*ON REQUEST,
ATEX CERTIFIED PRODUCTS
CAN BE SUPPLIED.*

CONTACT WESTCAR



WESTCAR WORLDWIDE



Albania	Finland	Peru
Australia	France	Poland
Belarus	Germany	Portugal
Belgium	Great Britain	Romania
Bosnia and Herzegovina	Greece	Russia
Brazil	Holland	Serbia
Canada	Iran	Singapore
Chile	Korea	Slovak Republic
China	Latvia	Slovenia
Colombia	Lithuania	South Africa
Croatia	Macedonia	Spain
Czech Republic	Morocco	Sweden
Denmark	New Zealand	Thailand
Egypt	Norway	Turkey
Estonia	Pakistan	USA

Distributor



WESTCAR s.r.l.

Headquarter

Via Monte Rosa, 14 - 20149 Milano (ITALY)

Ph. +39 02 761 10 319 - Fax +39 02 761 10 041

Production Plant

Via Venezia, 31 - 21058 Solbiate Olona (VA - ITALY)

info@westcar.it - www.westcar.it